

# 自動車安全性能2020

## Vehicle Safety Performance 2020

試験車名: Test vehicle:	トヨタ(TOYOTA) ヤリス(YARIS) X
------------------------	--------------------------------

自動車安全性能2020 総得点: Overall points of Vehicle Safety Performance 2020:	★★★★★ 5	91%	173.41 / 190 points
衝突安全性能評価: Collision safety performance evaluation:	ランク(Rank) A	87%	87.35 / 100 points
予防安全性能評価: Preventive safety performance evaluation:	ランク(Rank) A	95%	78.06 / 82 points
事故自動緊急通報装置: Automatic accident emergency call system:	先進型 Advanced type	100%	8 / 8 points

フルラップ前面衝突試験結果(55km/h) Test results of Full frontal collision safety performance test (55km/h)

試験車名 Model	ヤリス(YARIS)
試験車型式 Type	5BA-KSP210
試験番号 Test number	NASVA2020-02001
試験車重量 Test vehicle weight	1,142 kg

安全装置装備状況 Installation conditions of safety devices	1列目(First row)		2列目(Second row)			3列目(Third row)		
	運転席 Driver's seat	助手席 Front passenger's seat	運転席側 Driver side	助手席側 Front passenger side	中央席 Center seat	運転席側 Driver side	助手席側 Front passenger side	中央席 Center seat
エアバッグ Frontal airbag	○	○						
ニーエアバッグ Knee airbag	×	×						
サイドエアバッグ Side airbag	○	○						
サイドカーテンエアバッグ Side curtain airbag	○	○	○	○				
シートベルト・プリテンショナー Seat belt pretensioner	○	○	○	○	×			
シートベルト・フォース(ロード)リミッター Seat belt force (load) limiter	○	○	○	○	×			

○: 装備有り(Provided) ×: 装備無し(Not provided)

燃料漏れ Fuel leakage after collision	無 (None)
運転席の救出性 Rescueability of driver	人力 (Dummy could be removed by hand without moving the seat)
助手席の救出性 Rescueability of front passenger	人力 (Dummy could be removed by hand without moving the seat)
ドアの開閉性 Door openability	1列目 右側 First row driver side 片手 (Opened with one hand)
ドアロックの有無 Door locked	無 (None)

	2列目 右側 Second row driver side	1列目 左側 First row passenger side	2列目 左側 Second row passenger side
	片手 (Opened with one hand)	片手 (Opened with one hand)	片手 (Opened with one hand)
	無 (None)	無 (None)	無 (None)

乗員保護性能評価 Passenger protection performance

座席 Seat	部位 Each body area	評価項目 Injury criteria	単位 Unit	評価関数 Sliding rule		傷害値 Value	小計 Subtotal	重み係数 Weight	得点 Points	合計点 Overall points
				下限 Lower limit	上限 Upper limit					
運転席 Driver's seat	頭部 Head	頭部傷害値(HIC36) Head injury criterion(HIC36)	HIC	650	1000	326.6	4.00	0.923	3.69	9.48 / 12 79.0% Level 4 / 5
		ステアリング上方変位量 Steering wheel upper displacement	mm	72	88	0	0.00			
	頸部 Neck	せん断荷重 Shearing load	kN	範囲 Specified range		0.31	4.00	0.231	0.92	
		引張荷重 Tensile load	kN	範囲 Specified range		1.41	4.00			
		伸張モーメント Moment of extension	Nm	42	57	13.88	4.00			
	胸部 Chest	胸部変位量 Chest displacement	mm	22	42	25.81	3.24	0.923	2.99	
		胸部加速度(3ms-G) Resultant chest acceleration	m/s <sup>2</sup>	588以上 588 or higher			0.00			
		胸上部とステアリングの2次接触 Secondary contact of upper chest and steering wheel	-	-	-	無 (None)	0.00			
		ステアリング後方変位量 Steering wheel lower displacement	mm	90	110	0	0.00			
	下肢部 Legs	右大腿骨荷重 Right femur load	kN	7	10	1.74	2.00	0.923	1.87	
		左大腿骨荷重 Left femur load	kN	7	10	3.20				
		右上脛骨荷重指数(Tibia Index) Right upper Tibia Index	-	0.4	1.3	0.45	0.24			
		右下脛骨荷重指数(Tibia Index) Right lower Tibia Index	-	0.4	1.3	1.19				
		左上脛骨荷重指数(Tibia Index) Left upper Tibia Index	-	0.4	1.3	0.46				
		左下脛骨荷重指数(Tibia Index) Left lower Tibia Index	-	0.4	1.3	0.38	0.00			
		右上脛骨軸荷重(FZ) Right upper tibia axis load	kN	8	-	2.57				
		右下脛骨軸荷重(FZ) Right lower tibia axis load	kN	8	-	2.98				
		左上脛骨軸荷重(FZ) Left upper tibia axis load	kN	8	-	1.96				
		左下脛骨軸荷重(FZ) Left lower tibia axis load	kN	8	-	2.47				
	ブレーキペダル後方変位量 Brake pedal lower displacement	mm	100	200	121	-0.21				
ブレーキペダル上方変位量 Brake pedal upper displacement	mm	72	88	59	0.00					
助手席 Front passenger's seat	頭部 Head	頭部傷害値(HIC15) Head injury criterion(HIC15)	HIC	500	700	149.0	4.00	0.8	3.20	11.90 / 12 99.2% Level 5 / 5
	頸部 Neck	引張荷重 Tensile load	kN	1.70	2.62	0.79	4.00	0.2	0.80	
		せん断荷重 Shearing load	kN	1.20	1.95	0.30	4.00			
		伸張モーメント Moment of extension	Nm	36	49	21.18	4.00			
	胸部 Chest	胸部変位量 Chest displacement	mm	18	34	18.46	3.89	0.8	3.11	
	腹部 Abdomen	ラップベルトの骨盤からのずれ上がり Riding up of wrap belt from pelvis	-	-	-	無 (None)	4.00	0.8	3.20	
	下肢部 Legs	右大腿骨荷重 Right femur load	kN	4.8	6.8	1.02	4.00	0.4	1.60	
		左大腿骨荷重 Left femur load	kN	4.8	6.8	0.24	4.00			

感電保護性能評価 Performance test for electric shock protection after collision for electric vehicle
評価対象外 (Excluded)

特記事項 Special notes
-----------------------

オフセット前面衝突試験結果(64km/h) Test results of Offset frontal collision safety performance test (64km/h)

試験車名 Model	ヤリス (YARIS)	
試験車型式 Type	5BA-KSP210	
試験番号 Test number	NASVA2020-02011	
試験車重量 Test vehicle weight	1,139	kg

安全装置装備状況 Installation conditions of safety devices	1列目(First row)		2列目(Second row)			3列目(Third row)		
	運転席 Driver's seat	助手席 Front passenger's seat	運転席側 Driver side	助手席側 Front passenger side	中央席 Center seat	運転席側 Driver side	助手席側 Front passenger side	中央席 Center seat
エアバッグ Frontal airbag	○	○						
ニーエアバッグ Knee airbag	×	×						
サイドエアバッグ Side airbag	○	○						
サイドカーテンエアバッグ Side curtain air bag	○	○	○	○				
シートベルト・プリテンショナー Seat belt pretensioner	○	○	○	○	×			
シートベルト・フォース(ロード)リミッター Seat belt force (load) limiter	○	○	○	○	×			

○: 装備有り (Provided) ×: 装備無し (Not provided)

燃料漏れ Fuel leakage after collision	無 (None)	
運転席の救出性 Rescueability of driver	人力 (Dummy could be removed by hand without moving the seat)	
後席の救出性 Rescueability of rear passenger	人力 (Dummy could be removed by hand without moving the seat)	
ドアの開閉性 Door openability	1列目 右側 First row driver side	2列目 右側 Second row driver side
	片手 (Opened with one hand)	片手 (Opened with one hand)
ドアロックの有無 Door locked	無 (None)	

1列目 左側 First row passenger side		2列目 左側 Second row passenger side	
片手 (Opened with one hand)	片手 (Opened with one hand)	片手 (Opened with one hand)	片手 (Opened with one hand)
無 (None)		無 (None)	

乗員保護性能評価 Passenger protection performance

座席 Seat	部位 Each body area	評価項目 Injury criteria	単位 Unit	評価閾値 Sliding rule		傷害値 Value	小計 Subtotal	重み係数 Weight	得点 Points	合計点 Overall points
				下限 Lower limit	上限 Upper limit					
運転席 Driver's seat	頭部 Head	頭部傷害値(HIC36) Head injury criterion(HIC36)	HIC	650	1000	356.9	4.00	0.923	3.69	11.47 / 12 95.6% Level 5 / 5
		ステアリング上方変位量 Steering wheel upper displacement	mm	72	88	0	0.00			
	頸部 Neck	せん断荷重 Shearing load	kN	範囲 Specified range		0.37	4.00	0.231	0.92	
		引張荷重 Tensile load	kN	範囲 Specified range		1.74	4.00			
		伸張モーメント Moment of extension	Nm	42	57	13.47	4.00			
	胸部 Chest	胸部変位量 Chest displacement	mm	22	42	24.50	3.50	0.923	3.23	
		胸部加速度(3ms-G) Resultant chest acceleration	m/s <sup>2</sup>	588以上 588 or higher			0.00			
		胸上部とステアリングの2次接触 Secondary contact of upper chest and steering wheel	-	-	-	無 (None)	0.00			
		ステアリング後方変位量 Steering wheel lower displacement	mm	90	110	0	0.00			
	下肢部 Legs	右大腿骨荷重 Right femur load	kN	7	10	2.41	2.00	0.923	3.63	
		左大腿骨荷重 Left femur load	kN	7	10	0.84				
		右上脛骨荷重指数(Tibia Index) Right upper Tibia Index	-	0.4	1.3	0.43	1.93			
		右下脛骨荷重指数(Tibia Index) Right lower Tibia Index	-	0.4	1.3	0.24				
		左上脛骨荷重指数(Tibia Index) Left upper Tibia Index	-	0.4	1.3	0.28				
		左下脛骨荷重指数(Tibia Index) Left lower Tibia Index	-	0.4	1.3	0.22				
		右上脛骨軸荷重(FZ) Right upper tibia axis load	kN	8	-	1.90	0.00			
		右下脛骨軸荷重(FZ) Right lower tibia axis load	kN	8	-	2.44				
		左上脛骨軸荷重(FZ) Left upper tibia axis load	kN	8	-	1.75				
左下脛骨軸荷重(FZ) Left lower tibia axis load		kN	8	-	2.31					
ブレーキペダル後方変位量 Brake pedal lower displacement	mm	100	200	32	0.00					
ブレーキペダル上方変位量 Brake pedal upper displacement	mm	72	88	0	0.00					
後席 Rear passenger's seat	頭部 Head	頭部と車内部位との2次衝突 Dummy head comes into a secondary collision	-	-	-	無 (None)	0.00	0.8	3.20	
		頭部傷害値(HIC15) Head injury criterion(HIC15)	HIC	500	700		4.00			
	頸部 Neck	引張荷重 Tensile load	kN	1.70	2.62	1.29	4.00	0.2	0.80	
		せん断荷重 Shearing load	kN	1.2	1.95		4.00			
		伸張モーメント Moment of extension	Nm	36	49		4.00			
	胸部 Chest	胸部変位量 Chest displacement	mm	18	42	28.54	2.24	0.8	1.79	
	腹部 Abdomen	ラップベルトの骨盤からのずれ上がり Riding up of wrap belt from pelvis	-	-	-	無 (None)	4.00	0.8	3.20	
	下肢部 Legs	右大腿骨荷重 Right femur load	kN	4.8	6.8	0.11	4.00	0.4	1.60	
左大腿骨荷重 Left femur load		kN	4.8	6.8	0.11	4.00				

感電保護性能評価 Performance test for electric shock protection after collision for electric vehicle
評価対象外 (Excluded)

特記事項 Special notes
-----------------------

側面衝突試験結果(55km/h) Test results of Side collision safety performance test (55km/h)

試験車名 Model	ヤリス (YARIS)
試験車型式 Type	5BA-KSP210
試験番号 Test number	NASVA2020-02021
試験車重量 Test vehicle weight	1,035 kg

安全装置装備状況 Installation conditions of safety devices	1列目 (First row)		2列目 (Second row)			3列目 (Third row)		
	運転席 Driver's seat	助手席 Front passenger's seat	運転席側 Driver side	助手席側 Front passenger side	中央席 Center seat	運転席側 Driver side	助手席側 Front passenger side	中央席 Center seat
エアバッグ Frontal airbag	○	○						
ニーエアバッグ Knee airbag	×	×						
サイドエアバッグ Side airbag	○	○						
サイドカーテンエアバッグ Side curtain air bag	○	○	○	○				
シートベルト・プリテンショナー Seat belt pretensioner	○	○	○	○	×			
シートベルト・フォース(ロード)リミッター Seat belt force (load) limiter	○	○	○	○	×			

○: 装備有り (Provided) ×: 装備無し (Not provided)

燃料漏れ Fuel leakage after collision	無 (None)
車両の横転 Occurrence of turning-over of the test vehicle	無 (None)
ドアの開放 Door opened about its hinge during the collision	無 (None)
車室内の突起物 Breakage of devices or components in the vehicle	無 (None)
非衝突側の救出性 Rescueability of dummy from the test vehicle	人力 (Dummy could be removed by hand without moving the seat)

ドアの開扉性 Door openability	1列目 非衝突側 First row non-collision side	2列目 非衝突側 Second row non-collision side
	片手 (Opened with one hand)	片手 (Opened with one hand)
ドアロックの有無 Door locked	無 (None)	無 (None)

乗員保護性能評価 Passenger protection performance

座席 Seat	部位 Each body area	評価項目 Injury criteria	単位 Unit	評価関数 Sliding rule		傷害値 Value	小計 Subtotal	重み係数 Weight	得点 Points	合計点 Overall points
				下限 Lower limit	上限 Upper limit					
運転席 Driver's seat	頭部 Head	頭部傷害値(HIC15) Head injury criterion(HIC15)	HIC	500	700	123.1	4.00	1.0	4.00	12.00 / 12 100.0% Level 5 / 5
	肩部 Shoulder	肩部荷重 Shoulder load	kN	3.0	-	0.98	0.00	1.0	0.00	
	胸部 Chest	胸部変位量 Chest displacement	mm	28	50	16.87	4.00	1.0	4.00	
	腹部 Abdomen	腹部変位量 Abdomen displacement	mm	47	65	24.96	4.00	0.5	2.00	
	腰部 Lumbar	腰部荷重 Lumbar load	kN	1.7	2.8	1.17	4.00	0.5	2.00	

感電保護性能評価 Performance test for electric shock protection after collision for electric vehicle
評価対象外 (Excluded)

特記事項 Special notes	
-----------------------	--

## 後面衝突頸部保護性能試験結果

### Test results of Neck injury protection rear-end collision performance test

試験車名 Model	ヤリス(YARIS)
---------------	------------

座席 Seat	部位 Each body area	評価項目 Injury criteria	単位 Unit	評価関数 Sliding rule		傷害値 Value	小計 Subtotal	重み 係数 Weight	得点 Points	合計点 Overall points
				下限 Lower limit	上限 Upper limit					
運転席 Driver's seat	頸部 Neck	頸部傷害基準(NIC) Neck injury criterion	m <sup>2</sup> /s <sup>2</sup>	8	30	8.6	3.89	1	3.89	11.54 / 12 96.2% Level 5 / 5
	頸上部 Upper neck	せん断荷重(頭後方向)Fx Shearing load (back of the head)	N	340	730	32.4	4.00	2	7.66	
		引張荷重(上方向)Fz Tensile load (upper direction)	N	475	1130	123.9	4.00			
		左右方向軸まわりモーメント(屈曲) My Horizontal axial moment (Flexion)	Nm	12	40	13.2	3.83			
		左右方向軸まわりモーメント(伸展) My Horizontal axial moment (Extension)	Nm	12	40	7.7	4.00			
	頸下部 Lower neck	せん断荷重(頭後方向)Fx Shearing load (back of the head)	N	340	730	127.8	4.00	2	7.66	
		引張荷重(上方向)Fz Tensile load (upper direction)	N	257	1480	53.6	4.00			
		左右方向軸まわりモーメント(屈曲) My Horizontal axial moment (Flexion)	Nm	12	40	1.7	4.00			
		左右方向軸まわりモーメント(伸展) My Horizontal axial moment (Extension)	Nm	12	40	2.2	4.00			
	助手席 Front passeng er's seat	頸部 Neck	頸部傷害基準(NIC) Neck injury criterion	m <sup>2</sup> /s <sup>2</sup>	8	30	8.6	3.89	1	
頸上部 Upper neck		せん断荷重(頭後方向)Fx Shearing load (back of the head)	N	340	730	32.4	4.00	2	7.66	
		引張荷重(上方向)Fz Tensile load (upper direction)	N	475	1130	123.9	4.00			
		左右方向軸まわりモーメント(屈曲) My Horizontal axial moment (Flexion)	Nm	12	40	13.2	3.83			
		左右方向軸まわりモーメント(伸展) My Horizontal axial moment (Extension)	Nm	12	40	7.7	4.00			
頸下部 Lower neck		せん断荷重(頭後方向)Fx Shearing load (back of the head)	N	340	730	127.8	4.00	2	7.66	
		引張荷重(上方向)Fz Tensile load (upper direction)	N	257	1480	53.6	4.00			
		左右方向軸まわりモーメント(屈曲) My Horizontal axial moment (Flexion)	Nm	12	40	1.7	4.00			
		左右方向軸まわりモーメント(伸展) My Horizontal axial moment (Extension)	Nm	12	40	2.2	4.00			



シートベルトリマインダー(座席ベルトの非着用時警報装置)評価試験結果  
 Test results of Passenger Seat Belt Reminder (PSBR) evaluation test

試験車名 Model	ヤリス(YARIS)
---------------	------------

座席 Seat	装備 状況 Equipment condition	評価項目 Injury criteria	得点 Points	合計点 Overall points
助手席 Front passenge r's seat	○ 装備 あり (Provide d)	運転席から警報表示及び警報音を確認できる When the alarm indicator and the alarm sound can be confirmed from the driver seat	0.90	2.80 / 3.6 77.8% Level 4 / 5
		助手席から警報音を確認できる When the alarm sound can be confirmed from the front passenger seat	0.60	
後席 Rear passenge r's seat	○ 装備 あり (Provide d)	運転席から警報表示及び警報音を確認できる(チェンジオブステータス警報) When the alarm indicator and the alarm sound can be confirmed from the driver seat (the change of status alarm)	0.90	
		後席から警報表示を確認できる(後席ベルト警報) When the alarm indicator for the seat in question can be confirmed from the back seat (the back seatbelt alarm)	0.00	
		後席から警報表示を確認できる(チェンジオブステータス警報) When the alarm indicator for the seat in question can be confirmed from the back seat (the change of status alarm)	0.00	
		後席から警報音を確認できる(後席ベルト警報) When the audio alarm for the seat in question can be confirmed from the back seat (the back seatbelt alarm)	0.00	
		後席から警報音を確認できる(チェンジオブステータス警報) When the audio alarm for the seat in question can be confirmed from the back seat (the change of status alarm)	0.40	

被害軽減ブレーキ(対車両)試験結果 Test results of Autonomous Emergency Braking System[car to car] performance test

試験車名 Test vehicle	トヨタ(TOYOTA) ヤリス(YARIS) X
試験車型式 Type	6AA-MXPH10
車台番号 Frame number	MXPH10-2026787
試験番号 Test number	NASVA2020-02401
試験時重量 Test vehicle weight	1275.0kg
センサー方式 Sensor system	ミリ波レーダー・単眼カメラ Milliwave radar & Monocular camera
タイヤサイズ Tire	185/60R15 84H

AEBS 試験開始車速 AEBS activation lower limit speed	CCRs:10km/h	CCRm:35km/h
FCWS 試験開始車速 FCWS activation lower limit speed	CCRs:10km/h	CCRm:35km/h
AEBS 試験終了車速 AEBS activation upper limit speed	CCRs:60km/h	CCRm:60km/h
FCWS 試験終了車速 FCWS activation upper limit speed	CCRs:60km/h	CCRm:60km/h
FCWS機能の有無 FCWS Available or Not	有 (Available)	

試験シナリオ Test scenario	車速条件 Vehicle speed	AEBS試験 AEBS test	FCWS試験 FCWS test
CCRs	10 km/h	1.00	1.00
	15 km/h	1.00	1.00
	20 km/h	1.00	1.00
	25 km/h	1.00	1.00
	30 km/h	1.00	1.00
	35 km/h	2.00	2.00
	40 km/h	2.00	2.00
	45 km/h	1.50	1.50
	50 km/h	1.00	1.00
	55 km/h	0.50	0.50
CCRm	60 km/h	0.50	0.50
	35 km/h	0.50	0.50
	40 km/h	0.50	0.50
	45 km/h	1.00	1.00
	50 km/h	1.00	1.00
	55 km/h	0.50	0.50
60 km/h	0.50	0.50	
合計点 Overall points		<b>33.0 / 33</b> <b>Level 5 / 5</b>	



被害軽減ブレーキ(対車両)試験結果 Test results of Autonomous Emergency Braking System[car to car] performance test

(1) CCRsシナリオのAEBS試験  
CCR scenario AEBS test

車速条件 Vehicle speed	試験回数 Test #	回避可否 <sup>(*)</sup> Collision avoided?(*)	(a)	(b)	(c)=(a)-(b)	(d)=(c)/(a)	速度低減率 中央値 Velocity reduction rate median
			初期速度差 Initial velocity difference	衝突時 相対速度 Relative speed at collision	速度低減量 Velocity reduction amount	速度低減率 Velocity reduction rate	
10 km/h	1回目 1st	○	10.3	0.0	10.3	1.00	1.00
	2回目 2nd						
	3回目 3rd						
15 km/h	1回目 1st	P					1.00
	2回目 2nd						
	3回目 3rd						
20 km/h	1回目 1st	○	20.3	0.0	20.3	1.00	1.00
	2回目 2nd						
	3回目 3rd						
25 km/h	1回目 1st	P					1.00
	2回目 2nd						
	3回目 3rd						
30 km/h	1回目 1st	○	30.3	0.0	30.3	1.00	1.00
	2回目 2nd						
	3回目 3rd						
35 km/h	1回目 1st	P					1.00
	2回目 2nd						
	3回目 3rd						
40 km/h	1回目 1st	○	40.3	0.0	40.3	1.00	1.00
	2回目 2nd						
	3回目 3rd						
45 km/h	1回目 1st	P					1.00
	2回目 2nd						
	3回目 3rd						
50 km/h	1回目 1st	○	50.3	0.0	50.3	1.00	1.00
	2回目 2nd						
	3回目 3rd						
55 km/h	1回目 1st	P					1.00
	2回目 2nd						
	3回目 3rd						
60 km/h	1回目 1st	○	60.3	0.0	60.3	1.00	1.00
	2回目 2nd						
	3回目 3rd						

(\*) ○:衝突回避 Collision avoided、 P:パス(回避扱い) Passed (deemed avoided)、  
△:速度軽減 Speed reduced、 ×:不作為 No activation、 -:未実施 Not implemented

(2) CCRsシナリオのFCWS試験  
CCR scenario FCWS test

車速条件 Vehicle speed	試験回数 Test #	回避可否 <sup>(*)</sup> Collision avoided?(*)	(a)	(b)	(c)=(a)-(b)	(d)=(c)/(a)	速度低減率 中央値 Velocity reduction rate median
			初期速度差 Initial velocity difference	衝突時 相対速度 Relative speed at collision	速度低減量 Velocity reduction amount	速度低減率 Velocity reduction rate	
10 km/h	1回目 1st	○	10.3	0.0	10.3	1.00	1.00
	2回目 2nd						
	3回目 3rd						
15 km/h	1回目 1st	P					1.00
	2回目 2nd						
	3回目 3rd						
20 km/h	1回目 1st	○	20.3	0.0	20.3	1.00	1.00
	2回目 2nd						
	3回目 3rd						
25 km/h	1回目 1st	P					1.00
	2回目 2nd						
	3回目 3rd						
30 km/h	1回目 1st	○	30.3	0.0	30.3	1.00	1.00
	2回目 2nd						
	3回目 3rd						
35 km/h	1回目 1st	P					1.00
	2回目 2nd						
	3回目 3rd						
40 km/h	1回目 1st	○	40.3	0.0	40.3	1.00	1.00
	2回目 2nd						
	3回目 3rd						
45 km/h	1回目 1st	P					1.00
	2回目 2nd						
	3回目 3rd						
50 km/h	1回目 1st	○	50.3	0.0	50.3	1.00	1.00
	2回目 2nd						
	3回目 3rd						
55 km/h	1回目 1st	P					1.00
	2回目 2nd						
	3回目 3rd						
60 km/h	1回目 1st	○	60.3	0.0	60.3	1.00	1.00
	2回目 2nd						
	3回目 3rd						

(\*) ○:衝突回避 Collision avoided、 P:パス(回避扱い) Passed (deemed avoided)、  
△:速度軽減 Speed reduced、 ×:不作為 No activation、 -:未実施 Not implemented

被害軽減ブレーキ(対車両)試験結果 Test results of Autonomous Emergency Braking System[car to car] performance test

(3) CCRmシナリオのAEBS試験  
CCRm scenario AEBS test

(a) (b) (c)=(a)-(b) (d)=(c)/(a)

車速条件 Vehicle speed	試験回数 Test #	回避可否 <sup>(*)</sup> Collision avoided?(*)	初期速度差 Initial velocity difference	衝突時 相対速度 Relative speed at collision	速度低減量 Velocity reduction amount	速度低減率 Velocity reduction rate	速度低減率 中央値 Velocity reduction rate median
35 km/h	1回目 1st	○	14.9	0.0	14.9	1.00	1.00
	2回目 2nd						
	3回目 3rd						
40 km/h	1回目 1st	P					1.00
	2回目 2nd						
	3回目 3rd						
45 km/h	1回目 1st	○	25.0	0.0	25.0	1.00	1.00
	2回目 2nd						
	3回目 3rd						
50 km/h	1回目 1st	P					1.00
	2回目 2nd						
	3回目 3rd						
55 km/h	1回目 1st	○	34.8	0.0	34.8	1.00	1.00
	2回目 2nd						
	3回目 3rd						
60 km/h	1回目 1st	○	40.0	0.0	40.0	1.00	1.00
	2回目 2nd						
	3回目 3rd						

(\*) ○:衝突回避 Collision avoided、 P:パス(回避扱い) Passed (deemed avoided)、  
△:速度軽減 Speed reduced、 ×:不作用 No activation、 -:未実施 Not implemented

(4) CCRmシナリオのFCWS試験  
CCRm scenario FCWS test

(a) (b) (c)=(a)-(b) (d)=(c)/(a)

車速条件 Vehicle speed	試験回数 Test #	回避可否 <sup>(*)</sup> Collision avoided?(*)	初期速度差 Initial velocity difference	衝突時 相対速度 Relative speed at collision	速度低減量 Velocity reduction amount	速度低減率 Velocity reduction rate	速度低減率 中央値 Velocity reduction rate median
35 km/h	1回目 1st	○	14.9	0.0	14.9	1.00	1.00
	2回目 2nd						
	3回目 3rd						
40 km/h	1回目 1st	P					1.00
	2回目 2nd						
	3回目 3rd						
45 km/h	1回目 1st	○	25.0	0.0	25.0	1.00	1.00
	2回目 2nd						
	3回目 3rd						
50 km/h	1回目 1st	P					1.00
	2回目 2nd						
	3回目 3rd						
55 km/h	1回目 1st	○	34.8	0.0	34.8	1.00	1.00
	2回目 2nd						
	3回目 3rd						
60 km/h	1回目 1st	○	40.0	0.0	40.0	1.00	1.00
	2回目 2nd						
	3回目 3rd						

(\*) ○:衝突回避 Collision avoided、 P:パス(回避扱い) Passed (deemed avoided)、  
△:速度軽減 Speed reduced、 ×:不作用 No activation、 -:未実施 Not implemented

被害軽減ブレーキ(対歩行者:昼間)試験結果 Test results of Autonomous Emergency Braking System[for pedestrian daytime] performance test

試験車名 Test Vehicle	トヨタ(TOYOTA) ヤリス(YARIS) X
試験車型式 Type	6AA-MXPH10
車台番号 Frame number	MXPH10-2026787
試験番号 Test number	NASVA2020-02411
試験時重量 Test vehicle weight	1275.0kg
センサー方式 Sensor System	ミリ波レーダー・単眼カメラ Milliwave radar & Monocular camera
タイヤサイズ Tire	185/60R15 84H

AEBS 試験開始車速 AEBS activation lower limit speed	CPN:10km/h	CPNO:25km/h
FCWS 試験開始車速 FCWS activation lower limit speed	CPN:10km/h	CPNO:25km/h
AEBS 試験終了車速 AEBS activation upper limit speed	CPN:60km/h	CPNO:45km/h
FCWS 試験終了車速 FCWS activation upper limit speed	CPN:60km/h	CPNO:45km/h
FCWS機能の有無 FCWS Available or Not	有 (Available)	
部分評価試験における代表車速 Partial evaluation test representative speed	CPN:40km/h	CPNO:40km/h

AEBS試験 AEBS test

追加条件 Additional Conditions	CPN結果 CPN Results	補正係数 Correction Factor	CPN得点 CPN Score	CPNO結果 CPNO Results	補正係数 Correction Factor	CPNO得点 CPNO Score	評価得点 Evaluation score
ラップ率 Wrap rate	10.00	1.00	10.00	2.50	1.00	2.50	12.50
歩行速度 Pedestrian speed	10.00	1.00		2.50	1.00		
ターゲット PT	10.00	1.00		2.50	1.00		
補正無しの場合 Standard evaluation test results	10.00			2.50			

FCWS試験 FCWS test

追加条件 Additional Conditions	CPN結果 CPN Results	補正係数 Correction Factor	CPN得点 CPN Score	CPNO結果 CPNO Results	補正係数 Correction Factor	CPNO得点 CPNO Score	評価得点 Evaluation score
ラップ率 Wrap rate	10.00	1.00	10.00	2.50	1.00	2.50	12.50
歩行速度 Pedestrian speed	10.00	1.00		2.50	1.00		
ターゲット PT	10.00	1.00		2.50	1.00		
補正無しの場合 Standard evaluation test results	10.00			2.50			

合計点 Overall points	25.0 / 25 Level 5 / 5
-----------------------	--------------------------

被害軽減ブレーキ(対歩行者:昼間)試験結果 Test results of Autonomous Emergency Braking System[for pedestrian daytime] performance test

(1) 基準評価試験: CPNシナリオのAEBS試験

Standard evaluation test: CPN scenario AEBS test

車速条件 Vehicle Speed	試験回数 Test #	回避可否 <sup>(*)</sup> Collision Avoided?(*)	(a)	(b)	(c)=(a)-(b)	(d)=(c)/(a)	速度低減率 中央値 Velocity reduction rate median
			初期速度 Initial speed	衝突速度 Speed at collision	速度低減量 Velocity reduction amount	速度低減率 Velocity reduction rate	
10 km/h	1回目 1st	○	10.3	0.0	10.3	1.00	1.00
	2回目 2nd						
	3回目 3rd						
15 km/h	1回目 1st	P					1.00
	2回目 2nd						
	3回目 3rd						
20 km/h	1回目 1st	○	20.3	0.0	20.3	1.00	1.00
	2回目 2nd						
	3回目 3rd						
25 km/h	1回目 1st	P					1.00
	2回目 2nd						
	3回目 3rd						
30 km/h	1回目 1st	P					1.00
	2回目 2nd						
	3回目 3rd						
35 km/h	1回目 1st	P					1.00
	2回目 2nd						
	3回目 3rd						
40 km/h	1回目 1st	P					1.00
	2回目 2nd						
	3回目 3rd						
45 km/h	1回目 1st	P					1.00
	2回目 2nd						
	3回目 3rd						
50 km/h	1回目 1st	P					1.00
	2回目 2nd						
	3回目 3rd						
55 km/h	1回目 1st	○	55.2	0.0	55.2	1.00	1.00
	2回目 2nd						
	3回目 3rd						
60 km/h	1回目 1st	○	60.3	0.0	60.3	1.00	1.00
	2回目 2nd						
	3回目 3rd						

(\*) ○: 衝突回避 Collision avoided、P: パス(回避扱い) Passed (deemed avoided)、  
△: 速度軽減 Speed reduced、×: 不作動 No activation、-: 未実施 Not implemented

(2) 基準評価試験: CPNシナリオのFCWS試験

Standard evaluation test: CPN scenario FCWS test

車速条件 Vehicle Speed	試験回数 Test #	回避可否 <sup>(*)</sup> Collision Avoided?(*)	(a)	(b)	(c)=(a)-(b)	(d)=(c)/(a)	速度低減率 中央値 Velocity reduction rate median
			初期速度 Initial speed	衝突速度 Speed at collision	速度低減量 Velocity reduction amount	速度低減率 Velocity reduction rate	
10 km/h	1回目 1st	○	10.3	0.0	10.3	1.00	1.00
	2回目 2nd						
	3回目 3rd						
15 km/h	1回目 1st	P					1.00
	2回目 2nd						
	3回目 3rd						
20 km/h	1回目 1st	○	20.3	0.0	20.3	1.00	1.00
	2回目 2nd						
	3回目 3rd						
25 km/h	1回目 1st	P					1.00
	2回目 2nd						
	3回目 3rd						
30 km/h	1回目 1st	P					1.00
	2回目 2nd						
	3回目 3rd						
35 km/h	1回目 1st	P					1.00
	2回目 2nd						
	3回目 3rd						
40 km/h	1回目 1st	P					1.00
	2回目 2nd						
	3回目 3rd						
45 km/h	1回目 1st	P					1.00
	2回目 2nd						
	3回目 3rd						
50 km/h	1回目 1st	P					1.00
	2回目 2nd						
	3回目 3rd						
55 km/h	1回目 1st	○	55.2	0.0	55.2	1.00	1.00
	2回目 2nd						
	3回目 3rd						
60 km/h	1回目 1st	○	60.3	0.0	60.3	1.00	1.00
	2回目 2nd						
	3回目 3rd						

(\*) ○: 衝突回避 Collision avoided、P: パス(回避扱い) Passed (deemed avoided)、  
△: 速度軽減 Speed reduced、×: 不作動 No activation、-: 未実施 Not implemented

被害軽減ブレーキ(対歩行者:昼間)試験結果 Test results of Autonomous Emergency Braking System[for pedestrian daytime] performance test

(3) 基準評価試験：CPNOシナリオのAEBS試験

Standard evaluation test: CPNO scenario AEBS test

車速条件 Vehicle Speed	試験回数 Test #	回避可否 <sup>(*)</sup> Collision Avoided?(*)	(a)	(b)	(c)=(a)-(b)	(d)=(c)/(a)	速度低減率 中央値 Velocity reduction rate median
			初期速度 Initial speed	衝突速度 Speed at collision	速度低減量 Velocity reduction amount	速度低減率 Velocity reduction rate	
25 km/h	1回目 1st	○	25.3	0.0	25.3	1.00	1.00
	2回目 2nd						
	3回目 3rd						
30 km/h	1回目 1st	P					1.00
	2回目 2nd						
	3回目 3rd						
35 km/h	1回目 1st	○	35.3	0.0	35.3	1.00	1.00
	2回目 2nd						
	3回目 3rd						
40 km/h	1回目 1st	P					1.00
	2回目 2nd						
	3回目 3rd						
45 km/h	1回目 1st	○	45.3	0.0	45.3	1.00	1.00
	2回目 2nd						
	3回目 3rd						

(\*) ○: 衝突回避 Collision avoided、P: パス(回避扱い) Passed (deemed avoided)、  
△: 速度軽減 Speed reduced、×: 不作動 No activation、-: 未実施 Not implemented

(4) 基準評価試験：CPNOシナリオのFCWS試験

Standard evaluation test: CPNO scenario FCWS test

車速条件 Vehicle Speed	試験回数 Test #	回避可否 <sup>(*)</sup> Collision Avoided?(*)	(a)	(b)	(c)=(a)-(b)	(d)=(c)/(a)	速度低減率 中央値 Velocity reduction rate median
			初期速度 Initial speed	衝突速度 Speed at collision	速度低減量 Velocity reduction amount	速度低減率 Velocity reduction rate	
25 km/h	1回目 1st	○	25.3	0.0	25.3	1.00	1.00
	2回目 2nd						
	3回目 3rd						
30 km/h	1回目 1st	P					1.00
	2回目 2nd						
	3回目 3rd						
35 km/h	1回目 1st	○	35.3	0.0	35.3	1.00	1.00
	2回目 2nd						
	3回目 3rd						
40 km/h	1回目 1st	P					1.00
	2回目 2nd						
	3回目 3rd						
45 km/h	1回目 1st	○	45.3	0.0	45.3	1.00	1.00
	2回目 2nd						
	3回目 3rd						

(\*) ○: 衝突回避 Collision avoided、P: パス(回避扱い) Passed (deemed avoided)、  
△: 速度軽減 Speed reduced、×: 不作動 No activation、-: 未実施 Not implemented

被害軽減ブレーキ(対歩行者:昼間)試験結果 Test results of Autonomous Emergency Braking System[for pedestrian daytime] performance test

(5) 部分評価試験：CPNシナリオのAEBS試験

Partial evaluation test: CPN scenario AEBS test

○ラップ率 25%

Wrap rate 25%

(a) (b) (c)=(a)-(b) (d)=(c)/(a)

車速条件 Vehicle Speed	試験回数 Test #	回避可否 <sup>(*)</sup> Collision Avoided?(*)	初期速度 Initial speed	衝突速度 Speed at collision	速度低減量 Velocity reduction amount	速度低減率 Velocity reduction rate	速度低減率 中央値 Velocity reduction rate median
40 km/h	1回目 1st	○	40.3	0.0	40.3	1.00	1.00
	2回目 2nd						
	3回目 3rd						

○ラップ率 75%

Wrap rate 75%

(a) (b) (c)=(a)-(b) (d)=(c)/(a)

車速条件 Vehicle Speed	試験回数 Test #	回避可否 <sup>(*)</sup> Collision Avoided?(*)	初期速度 Initial speed	衝突速度 Speed at collision	速度低減量 Velocity reduction amount	速度低減率 Velocity reduction rate	速度低減率 中央値 Velocity reduction rate median
40 km/h	1回目 1st	P					1.00
	2回目 2nd						
	3回目 3rd						

○歩行速度 8km/h

Pedestrian speed 8km/h

(a) (b) (c)=(a)-(b) (d)=(c)/(a)

車速条件 Vehicle Speed	試験回数 Test #	回避可否 <sup>(*)</sup> Collision Avoided?(*)	初期速度 Initial speed	衝突速度 Speed at collision	速度低減量 Velocity reduction amount	速度低減率 Velocity reduction rate	速度低減率 中央値 Velocity reduction rate median
40 km/h	1回目 1st	○	40.3	0.0	40.3	1.00	1.00
	2回目 2nd						
	3回目 3rd						

○子供ダミー Child dummy

(a) (b) (c)=(a)-(b) (d)=(c)/(a)

車速条件 Vehicle Speed	試験回数 Test #	回避可否 <sup>(*)</sup> Collision Avoided?(*)	初期速度 Initial speed	衝突速度 Speed at collision	速度低減量 Velocity reduction amount	速度低減率 Velocity reduction rate	速度低減率 中央値 Velocity reduction rate median
40 km/h	1回目 1st	○	40.3	0.0	40.3	1.00	1.00
	2回目 2nd						
	3回目 3rd						

(\*) ○: 衝突回避 Collision avoided、P: パス(回避扱い) Passed (deemed avoided)、

△: 速度軽減 Speed reduced、×: 不作動 No activation、-: 未実施 Not implemented

(6) 部分評価試験：CPNシナリオのFCWS試験

Partial evaluation test: CPN scenario FCWS test

○ラップ率 25%

Wrap rate 25%

(a) (b) (c)=(a)-(b) (d)=(c)/(a)

車速条件 Vehicle Speed	試験回数 Test #	回避可否 <sup>(*)</sup> Collision Avoided?(*)	初期速度 Initial speed	衝突速度 Speed at collision	速度低減量 Velocity reduction amount	速度低減率 Velocity reduction rate	速度低減率 中央値 Velocity reduction rate median
40 km/h	1回目 1st	○	40.3	0.0	40.3	1.00	1.00
	2回目 2nd						
	3回目 3rd						

○ラップ率 75%

Wrap rate 75%

(a) (b) (c)=(a)-(b) (d)=(c)/(a)

車速条件 Vehicle Speed	試験回数 Test #	回避可否 <sup>(*)</sup> Collision Avoided?(*)	初期速度 Initial speed	衝突速度 Speed at collision	速度低減量 Velocity reduction amount	速度低減率 Velocity reduction rate	速度低減率 中央値 Velocity reduction rate median
40 km/h	1回目 1st	P					1.00
	2回目 2nd						
	3回目 3rd						

○歩行速度 8km/h

Pedestrian speed 8km/h

(a) (b) (c)=(a)-(b) (d)=(c)/(a)

車速条件 Vehicle Speed	試験回数 Test #	回避可否 <sup>(*)</sup> Collision Avoided?(*)	初期速度 Initial speed	衝突速度 Speed at collision	速度低減量 Velocity reduction amount	速度低減率 Velocity reduction rate	速度低減率 中央値 Velocity reduction rate median
40 km/h	1回目 1st	○	40.3	0.0	40.3	1.00	1.00
	2回目 2nd						
	3回目 3rd						

○子供ダミー Child dummy

(a) (b) (c)=(a)-(b) (d)=(c)/(a)

車速条件 Vehicle Speed	試験回数 Test #	回避可否 <sup>(*)</sup> Collision Avoided?(*)	初期速度 Initial speed	衝突速度 Speed at collision	速度低減量 Velocity reduction amount	速度低減率 Velocity reduction rate	速度低減率 中央値 Velocity reduction rate median
40 km/h	1回目 1st	○	40.3	0.0	40.3	1.00	1.00
	2回目 2nd						
	3回目 3rd						

(\*) ○: 衝突回避 Collision avoided、P: パス(回避扱い) Passed (deemed avoided)、

△: 速度軽減 Speed reduced、×: 不作動 No activation、-: 未実施 Not implemented

被害軽減ブレーキ(対歩行者:昼間)試験結果 Test results of Autonomous Emergency Braking System[for pedestrian daytime] performance test

(7) 部分評価試験：CPNOシナリオのAEBS試験

Partial evaluation test: CPNO scenario AEBS test

○子供ダミー Child dummy

車速条件 Vehicle Speed	試験回数 Test #	回避可否 <sup>(*)</sup> Collision Avoided?(*)	(a)	(b)	(c)=(a)-(b)	(d)=(c)/(a)	速度低減率 中央値 Velocity reduction rate median
			初期速度 Initial speed	衝突速度 Speed at collision	速度低減量 Velocity reduction amount	速度低減率 Velocity reduction rate	
40 km/h	1回目 1st	○	40.3	0.0	40.3	1.00	1.00
	2回目 2nd						
	3回目 3rd						

(\*) ○: 衝突回避 Collision avoided、P: パス(回避扱い) Passed (deemed avoided)、

△: 速度軽減 Speed reduced、×: 不作動 No activation、-: 未実施 Not implemented

(8) 部分評価試験：CPNOシナリオのFCWS試験

Partial evaluation test: CPNO scenario FCWS test

○子供ダミー Child dummy

車速条件 Vehicle Speed	試験回数 Test #	回避可否 <sup>(*)</sup> Collision Avoided?(*)	(a)	(b)	(c)=(a)-(b)	(d)=(c)/(a)	速度低減率 中央値 Velocity reduction rate median
			初期速度 Initial speed	衝突速度 Speed at collision	速度低減量 Velocity reduction amount	速度低減率 Velocity reduction rate	
40 km/h	1回目 1st	○	40.3	0.0	40.3	1.00	1.00
	2回目 2nd						
	3回目 3rd						

(\*) ○: 衝突回避 Collision avoided、P: パス(回避扱い) Passed (deemed avoided)、

△: 速度軽減 Speed reduced、×: 不作動 No activation、-: 未実施 Not implemented

被害軽減ブレーキ(対歩行者:夜間)試験結果 Test results of Autonomous Emergency Braking System[for pedestrian at night] performance test

試験車名 Test Vehicle	トヨタ(TOYOTA) ヤリス(YARIS) X
試験車型式 Type	6AA-MXPH10
車台番号 Frame number	MXPH10-2026787
試験番号 Test number	NASVA2020-02421
試験時重量 Test vehicle weight	1275.0kg
センサー方式 Sensor System	ミリ波レーダー・単眼カメラ Milliwave radar & Monocular camera
タイヤサイズ Tire	185/60R15 84H

街灯ありシナリオ 試験条件  
Test conditions setup(scenario with surrounding light)

AEBS 試験開始車速 AEBS activation lower limit speed	CPF:30km/h	CPFO:30km/h
FCWS 試験開始車速 FCWS activation lower limit speed	CPF:30km/h	CPFO:30km/h
AEBS 試験終了車速 AEBS activation upper limit speed	CPF:60km/h	CPFO:60km/h
FCWS 試験終了車速 FCWS activation upper limit speed	CPF:60km/h	CPFO:60km/h
FCWS機能の有無 FCWS Available or Not	有 (Available)	
部分評価試験における代表車速 Partial evaluation test representative speed	CPF:45km/h	

街灯なしシナリオ 試験条件  
Test conditions setup (scenario without surrounding light)

AEBS 試験開始車速 AEBS activation lower limit speed	CPF:30km/h	CPFO:40km/h
FCWS 試験開始車速 FCWS activation lower limit speed	CPF:30km/h	CPFO:40km/h
AEBS 試験終了車速 AEBS activation upper limit speed	CPF:60km/h	CPFO:50km/h
FCWS 試験終了車速 FCWS activation upper limit speed	CPF:60km/h	CPFO:50km/h
FCWS機能の有無 FCWS Available or Not	有 (Available)	
部分評価試験における代表車速 Partial evaluation test representative speed	CPF:45km/h	
試験時の前照灯 Headlight status of the testing	高機能前照灯(オート) High-performance headlamp(set to auto position)	

街灯ありシナリオ AEBS試験 AEBS test with surrounding light scenario

追加条件 Additional Conditions	CPF結果 CPF Results	補正係数 Correction Factor	CPF得点 CPF Score	CPFO結果 CPFO Results	補正係数 Correction Factor	CPFO得点 CPFO Score	評価得点 Evaluation score
ラップ率 Wrap rate	15.46	1.00	15.46	4.00	1.00	4.00	19.46
歩行速度 Pedestrian speed	15.46	1.00		4.00	1.00		
補正無しの場合 Standard evaluation test results	15.46			4.00			

街灯ありシナリオ FCWS試験 FCWS test with surrounding light scenario

追加条件 Additional Conditions	CPF結果 CPF Results	補正係数 Correction Factor	CPF得点 CPF Score	CPFO結果 CPFO Results	補正係数 Correction Factor	CPFO得点 CPFO Score	評価得点 Evaluation score
ラップ率 Wrap rate	15.45	1.00	15.45	4.00	1.00	4.00	19.45
歩行速度 Pedestrian speed	15.45	1.00		4.00	1.00		
補正無しの場合 Standard evaluation test results	15.45			4.00			

街灯なしシナリオ AEBS試験 AEBS test without surrounding light scenario

追加条件 Additional Conditions	CPF結果 CPF Results	補正係数 Correction Factor	CPF得点 CPF Score	CPFO結果 CPFO Results	補正係数 Correction Factor	CPFO得点 CPFO Score	評価得点 Evaluation score
ラップ率 Wrap rate	6.00	1.00	6.00	1.28	1.00	1.28	7.28
歩行速度 Pedestrian speed	6.00	1.00		1.28	1.00		
補正無しの場合 Standard evaluation test results	6.00			1.28			

街灯なしシナリオ FCWS試験 FCWS test without surrounding light scenario

追加条件 Additional Conditions	CPF結果 CPF Results	補正係数 Correction Factor	CPF得点 CPF Score	CPFO結果 CPFO Results	補正係数 Correction Factor	CPFO得点 CPFO Score	評価得点 Evaluation score
ラップ率 Wrap rate	6.00	1.00	6.00	1.28	1.00	1.28	7.28
歩行速度 Pedestrian speed	6.00	1.00		1.28	1.00		
補正無しの場合 Standard evaluation test results	6.00			1.28			

合計点 Overall points	53.5 / 55 Level 5 / 5
-----------------------	--------------------------



被害軽減ブレーキ(対歩行者:夜間[街灯あり])試験結果 Test results of Autonomous Emergency Braking System[for pedestrian at night] performance test (Nighttime test with surrounding light)

(1) 基準評価試験: CPFシナリオのAEBS試験

Standard evaluation test: CPF scenario AEBS test

(a) (b) (c)=(a)-(b) (d)=(c)/(a)

車速条件 Vehicle Speed	試験回数 Test #	回避可否 <sup>(*)</sup> Collision Avoided?(*)	初期速度 Initial speed	衝突速度 Speed at collision	速度低減量 Velocity reduction amount	速度低減率 Velocity reduction rate	速度低減率 中央値 Velocity reduction rate median
30 km/h	1回目 1st	○	30.3	0.0	30.3	1.00	1.00
	2回目 2nd	○	30.3	0.0	30.3	1.00	
	3回目 3rd						
35 km/h	1回目 1st	P					1.00
	2回目 2nd						
	3回目 3rd						
40 km/h	1回目 1st	○	40.3	0.0	40.3	1.00	1.00
	2回目 2nd	○	40.3	0.0	40.3	1.00	
	3回目 3rd						
45 km/h	1回目 1st	P					1.00
	2回目 2nd						
	3回目 3rd						
50 km/h	1回目 1st	○	50.2	0.0	50.2	1.00	1.00
	2回目 2nd	○	50.2	0.0	50.2	1.00	
	3回目 3rd						
55 km/h	1回目 1st	○	55.3	0.0	55.3	1.00	1.00
	2回目 2nd	○	55.3	0.0	55.3	1.00	
	3回目 3rd						
60 km/h	1回目 1st	○	60.3	0.0	60.3	1.00	0.64
	2回目 2nd	△	60.3	32.5	27.8	0.46	
	3回目 3rd	△	60.3	21.5	38.8	0.64	

(\*) ○: 衝突回避 Collision avoided、P: パス(回避扱い) Passed (deemed avoided)、  
△: 速度軽減 Speed reduced、×: 不作動 No activation、-: 未実施 Not implemented

(2) 基準評価試験: CPFシナリオのFCWS試験

Standard evaluation test: CPF scenario FCWS test

(a) (b) (c)=(a)-(b) (d)=(c)/(a)

車速条件 Vehicle Speed	試験回数 Test #	回避可否 <sup>(*)</sup> Collision Avoided?(*)	初期速度 Initial speed	衝突速度 Speed at collision	速度低減量 Velocity reduction amount	速度低減率 Velocity reduction rate	速度低減率 中央値 Velocity reduction rate median
30 km/h	1回目 1st	○	30.3	0.0	30.3	1.00	1.00
	2回目 2nd	○	30.3	0.0	30.3	1.00	
	3回目 3rd						
35 km/h	1回目 1st	P					1.00
	2回目 2nd						
	3回目 3rd						
40 km/h	1回目 1st	○	40.3	0.0	40.3	1.00	1.00
	2回目 2nd	○	40.3	0.0	40.3	1.00	
	3回目 3rd						
45 km/h	1回目 1st	P					1.00
	2回目 2nd						
	3回目 3rd						
50 km/h	1回目 1st	○	50.2	0.0	50.2	1.00	1.00
	2回目 2nd	○	50.2	0.0	50.2	1.00	
	3回目 3rd						
55 km/h	1回目 1st	○	55.3	0.0	55.3	1.00	1.00
	2回目 2nd	○	55.3	0.0	55.3	1.00	
	3回目 3rd						
60 km/h	1回目 1st	△	60.3	15.7	44.6	0.74	0.63
	2回目 2nd	△	60.3	34.5	25.8	0.43	
	3回目 3rd	△	60.3	22.1	38.2	0.63	

(\*) ○: 衝突回避 Collision avoided、P: パス(回避扱い) Passed (deemed avoided)、  
△: 速度軽減 Speed reduced、×: 不作動 No activation、-: 未実施 Not implemented

被害軽減ブレーキ(対歩行者:夜間[街灯あり])試験結果 Test results of Autonomous Emergency Braking System[for pedestrian at night] performance test (Nighttime test with surrounding light)

(3) 基準評価試験: CPFOシナリオのAEBS試験

(4) 基準評価試験: CPFOシナリオのFCWS試験

Standard evaluation test: CPFO scenario AEBS test

Standard evaluation test: CPFO scenario FCWS test

車速条件 Vehicle Speed	試験回数 Test #	回避可否 <sup>(*)</sup> Collision Avoided?(*)	(a)	(b)	(c)=(a)-(b)	(d)=(c)/(a)	速度低減率 中央値 Velocity reduction rate median
			初期速度 Initial speed	衝突速度 Speed at collision	速度低減量 Velocity reduction amount	速度低減率 Velocity reduction rate	
30 km/h	1回目 1st	○	30.3	0.0	30.3	1.00	1.00
	2回目 2nd	○	30.3	0.0	30.3	1.00	
	3回目 3rd						
35 km/h	1回目 1st	P					1.00
	2回目 2nd						
	3回目 3rd						
40 km/h	1回目 1st	○	40.3	0.0	40.3	1.00	1.00
	2回目 2nd	○	40.3	0.0	40.3	1.00	
	3回目 3rd						
45 km/h	1回目 1st	P					1.00
	2回目 2nd						
	3回目 3rd						
50 km/h	1回目 1st	○	50.3	0.0	50.3	1.00	1.00
	2回目 2nd	○	50.3	0.0	50.3	1.00	
	3回目 3rd						
55 km/h	1回目 1st	P					1.00
	2回目 2nd						
	3回目 3rd						
60 km/h	1回目 1st	△	60.2	34.3	25.9	0.43	1.00
	2回目 2nd	○	60.3	0.0	60.3	1.00	
	3回目 3rd	○	60.3	0.0	60.3	1.00	

(\*) ○: 衝突回避 Collision avoided、P: パス(回避扱い) Passed (deemed avoided)、  
△: 速度軽減 Speed reduced、×: 不作動 No activation、-: 未実施 Not implemented

車速条件 Vehicle Speed	試験回数 Test #	回避可否 <sup>(*)</sup> Collision Avoided?(*)	(a)	(b)	(c)=(a)-(b)	(d)=(c)/(a)	速度低減率 中央値 Velocity reduction rate median
			初期速度 Initial speed	衝突速度 Speed at collision	速度低減量 Velocity reduction amount	速度低減率 Velocity reduction rate	
30 km/h	1回目 1st	○	30.3	0.0	30.3	1.00	1.00
	2回目 2nd	○	30.3	0.0	30.3	1.00	
	3回目 3rd						
35 km/h	1回目 1st	P					1.00
	2回目 2nd						
	3回目 3rd						
40 km/h	1回目 1st	○	40.3	0.0	40.3	1.00	1.00
	2回目 2nd	○	40.3	0.0	40.3	1.00	
	3回目 3rd						
45 km/h	1回目 1st	P					1.00
	2回目 2nd						
	3回目 3rd						
50 km/h	1回目 1st	○	50.3	0.0	50.3	1.00	1.00
	2回目 2nd	○	50.3	0.0	50.3	1.00	
	3回目 3rd						
55 km/h	1回目 1st	P					1.00
	2回目 2nd						
	3回目 3rd						
60 km/h	1回目 1st	△	60.2	34.3	25.9	0.43	1.00
	2回目 2nd	○	60.3	0.0	60.3	1.00	
	3回目 3rd	○	60.3	0.0	60.3	1.00	

(\*) ○: 衝突回避 Collision avoided、P: パス(回避扱い) Passed (deemed avoided)、  
△: 速度軽減 Speed reduced、×: 不作動 No activation、-: 未実施 Not implemented

被害軽減ブレーキ(対歩行者:夜間[街灯あり])試験結果 Test results of Autonomous Emergency Braking System[for pedestrian at night] performance test (Nighttime test with surrounding light)

(5) 部分評価試験: CPFシナリオのAEBS試験

Partial evaluation test: CPF scenario AEBS test

○ラップ率 25%

Wrap rate 25%

(a) (b) (c)=(a)-(b) (d)=(c)/(a)

車速条件 Vehicle Speed	試験回数 Test #	回避可否 <sup>(*)</sup> Collision Avoided?(*)	初期速度 Initial speed	衝突速度 Speed at collision	速度低減量 Velocity reduction amount	速度低減率 Velocity reduction rate	速度低減率 中央値 Velocity reduction rate median
45 km/h	1回目 1st	○	45.2	0.0	45.2	1.00	1.00
	2回目 2nd	○	45.3	0.0	45.3	1.00	
	3回目 3rd						

○ラップ率 75%

Wrap rate 75%

(a) (b) (c)=(a)-(b) (d)=(c)/(a)

車速条件 Vehicle Speed	試験回数 Test #	回避可否 <sup>(*)</sup> Collision Avoided?(*)	初期速度 Initial speed	衝突速度 Speed at collision	速度低減量 Velocity reduction amount	速度低減率 Velocity reduction rate	速度低減率 中央値 Velocity reduction rate median
45 km/h	1回目 1st	P					1.00
	2回目 2nd						
	3回目 3rd						

○歩行速度 8km/h

Pedestrian speed 8km/h

(a) (b) (c)=(a)-(b) (d)=(c)/(a)

車速条件 Vehicle Speed	試験回数 Test #	回避可否 <sup>(*)</sup> Collision Avoided?(*)	初期速度 Initial speed	衝突速度 Speed at collision	速度低減量 Velocity reduction amount	速度低減率 Velocity reduction rate	速度低減率 中央値 Velocity reduction rate median
45 km/h	1回目 1st	○	45.3	0.0	45.3	1.00	1.00
	2回目 2nd	○	45.3	0.0	45.3	1.00	
	3回目 3rd						

(\*) ○: 衝突回避 Collision avoided、P: パス(回避扱い) Passed (deemed avoided)、

△: 速度軽減 Speed reduced、×: 不動作 No activation、-: 未実施 Not implemented

(6) 部分評価試験: CPFシナリオのFCWS試験

Partial evaluation test: CPF scenario FCWS test

○ラップ率 25%

Wrap rate 25%

(a) (b) (c)=(a)-(b) (d)=(c)/(a)

車速条件 Vehicle Speed	試験回数 Test #	回避可否 <sup>(*)</sup> Collision Avoided?(*)	初期速度 Initial speed	衝突速度 Speed at collision	速度低減量 Velocity reduction amount	速度低減率 Velocity reduction rate	速度低減率 中央値 Velocity reduction rate median
45 km/h	1回目 1st	○	45.2	0.0	45.2	1.00	1.00
	2回目 2nd	○	45.3	0.0	45.3	1.00	
	3回目 3rd						

○ラップ率 75%

Wrap rate 75%

(a) (b) (c)=(a)-(b) (d)=(c)/(a)

車速条件 Vehicle Speed	試験回数 Test #	回避可否 <sup>(*)</sup> Collision Avoided?(*)	初期速度 Initial speed	衝突速度 Speed at collision	速度低減量 Velocity reduction amount	速度低減率 Velocity reduction rate	速度低減率 中央値 Velocity reduction rate median
45 km/h	1回目 1st	P					1.00
	2回目 2nd						
	3回目 3rd						

○歩行速度 8km/h

Pedestrian speed 8km/h

(a) (b) (c)=(a)-(b) (d)=(c)/(a)

車速条件 Vehicle Speed	試験回数 Test #	回避可否 <sup>(*)</sup> Collision Avoided?(*)	初期速度 Initial speed	衝突速度 Speed at collision	速度低減量 Velocity reduction amount	速度低減率 Velocity reduction rate	速度低減率 中央値 Velocity reduction rate median
45 km/h	1回目 1st	○	45.3	0.0	45.3	1.00	1.00
	2回目 2nd	○	45.3	0.0	45.3	1.00	
	3回目 3rd						

(\*) ○: 衝突回避 Collision avoided、P: パス(回避扱い) Passed (deemed avoided)、

△: 速度軽減 Speed reduced、×: 不動作 No activation、-: 未実施 Not implemented

被害軽減ブレーキ(対歩行者:夜間[街灯なし])試験結果 Test results of Autonomous Emergency Braking System[for pedestrian at night] performance test (Nighttime test without surrounding light)

(1) 基準評価試験: CPFシナリオのAEBS試験

Standard evaluation test: CPF scenario AEBS test

車速条件 Vehicle Speed	試験回数 Test #	回避可否 <sup>(*)</sup> Collision Avoided?(*)	(a)	(b)	(c)=(a)-(b)	(d)=(c)/(a)	速度低減率 中央値 Velocity reduction rate median
			初期速度 Initial speed	衝突速度 Speed at collision	速度低減量 Velocity reduction amount	速度低減率 Velocity reduction rate	
30 km/h	1回目 1st	○	30.3	0.0	30.3	1.00	1.00
	2回目 2nd	○	30.3	0.0	30.3	1.00	
	3回目 3rd						
35 km/h	1回目 1st	P					1.00
	2回目 2nd						
	3回目 3rd						
40 km/h	1回目 1st	○	40.3	0.0	40.3	1.00	1.00
	2回目 2nd	○	40.3	0.0	40.3	1.00	
	3回目 3rd						
45 km/h	1回目 1st	P					1.00
	2回目 2nd						
	3回目 3rd						
50 km/h	1回目 1st	○	50.3	0.0	50.3	1.00	1.00
	2回目 2nd	○	50.3	0.0	50.3	1.00	
	3回目 3rd						
55 km/h	1回目 1st	P					1.00
	2回目 2nd						
	3回目 3rd						
60 km/h	1回目 1st	○	60.3	0.0	60.3	1.00	1.00
	2回目 2nd	○	60.3	0.0	60.3	1.00	
	3回目 3rd						

(\*) ○: 衝突回避 Collision avoided、 P: パス(回避扱い) Passed (deemed avoided)、  
△: 速度軽減 Speed reduced、 ×: 不作動 No activation、 -: 未実施 Not implemented

(2) 基準評価試験: CPFシナリオのFCWS試験

Standard evaluation test: CPF scenario FCWS test

車速条件 Vehicle Speed	試験回数 Test #	回避可否 <sup>(*)</sup> Collision Avoided?(*)	(a)	(b)	(c)=(a)-(b)	(d)=(c)/(a)	速度低減率 中央値 Velocity reduction rate median
			初期速度 Initial speed	衝突速度 Speed at collision	速度低減量 Velocity reduction amount	速度低減率 Velocity reduction rate	
30 km/h	1回目 1st	○	30.3	0.0	30.3	1.00	1.00
	2回目 2nd	○	30.3	0.0	30.3	1.00	
	3回目 3rd						
35 km/h	1回目 1st	P					1.00
	2回目 2nd						
	3回目 3rd						
40 km/h	1回目 1st	○	40.3	0.0	40.3	1.00	1.00
	2回目 2nd	○	40.3	0.0	40.3	1.00	
	3回目 3rd						
45 km/h	1回目 1st	P					1.00
	2回目 2nd						
	3回目 3rd						
50 km/h	1回目 1st	○	50.3	0.0	50.3	1.00	1.00
	2回目 2nd	○	50.3	0.0	50.3	1.00	
	3回目 3rd						
55 km/h	1回目 1st	P					1.00
	2回目 2nd						
	3回目 3rd						
60 km/h	1回目 1st	○	60.3	0.0	60.3	1.00	1.00
	2回目 2nd	○	60.3	0.0	60.3	1.00	
	3回目 3rd						

(\*) ○: 衝突回避 Collision avoided、 P: パス(回避扱い) Passed (deemed avoided)、  
△: 速度軽減 Speed reduced、 ×: 不作動 No activation、 -: 未実施 Not implemented

被害軽減ブレーキ(対歩行者:夜間[街灯なし])試験結果 Test results of Autonomous Emergency Braking System[for pedestrian at night] performance test (Nighttime test without surrounding light)

(3) 基準評価試験：CPFOシナリオのAEBS試験

(4) 基準評価試験：CPFOシナリオのFCWS試験

Standard evaluation test: CPFO scenario AEBS test

Standard evaluation test: CPFO scenario FCWS test

(a) (b) (c)=(a)-(b) (d)=(c)/(a)

車速条件 Vehicle Speed	試験回数 Test #	回避可否 <sup>(*)</sup> Collision Avoided?(*)	初期速度 Initial speed	衝突速度 Speed at collision	速度低減量 Velocity reduction amount	速度低減率 Velocity reduction rate	速度低減率 中央値 Velocity reduction rate median
40 km/h	1回目 1st	○	40.3	0.0	40.3	1.00	1.00
	2回目 2nd	○	40.3	0.0	40.3	1.00	
	3回目 3rd						
45 km/h	1回目 1st	○	45.3	0.0	45.3	1.00	1.00
	2回目 2nd	○	45.3	0.0	45.3	1.00	
	3回目 3rd						
50 km/h	1回目 1st	△	50.3	22.2	28.1	0.56	0.56
	2回目 2nd	△	50.3	22.4	27.9	0.55	
	3回目 3rd	△	50.3	21.1	29.2	0.58	

(\*) ○: 衝突回避 Collision avoided、P: パス(回避扱い) Passed (deemed avoided)、  
△: 速度軽減 Speed reduced、×: 不作動 No activation、-: 未実施 Not implemented

(a) (b) (c)=(a)-(b) (d)=(c)/(a)

車速条件 Vehicle Speed	試験回数 Test #	回避可否 <sup>(*)</sup> Collision Avoided?(*)	初期速度 Initial speed	衝突速度 Speed at collision	速度低減量 Velocity reduction amount	速度低減率 Velocity reduction rate	速度低減率 中央値 Velocity reduction rate median
40 km/h	1回目 1st	○	40.3	0.0	40.3	1.00	1.00
	2回目 2nd	○	40.3	0.0	40.3	1.00	
	3回目 3rd						
45 km/h	1回目 1st	○	45.3	0.0	45.3	1.00	1.00
	2回目 2nd	○	45.3	0.0	45.3	1.00	
	3回目 3rd						
50 km/h	1回目 1st	△	50.3	22.2	28.1	0.56	0.56
	2回目 2nd	△	50.3	22.4	27.9	0.55	
	3回目 3rd	△	50.3	21.1	29.2	0.58	

(\*) ○: 衝突回避 Collision avoided、P: パス(回避扱い) Passed (deemed avoided)、  
△: 速度軽減 Speed reduced、×: 不作動 No activation、-: 未実施 Not implemented

被害軽減ブレーキ(対歩行者:夜間[街灯なし])試験結果 Test results of Autonomous Emergency Braking System[for pedestrian at night] performance test (Nighttime test without surrounding light)

(5) 部分評価試験: CPFシナリオのAEBS試験

Partial evaluation test: CPF scenario AEBS test

○ラップ率 25%

Wrap rate 25%

(a) (b) (c)=(a)-(b) (d)=(c)/(a)

車速条件 Vehicle Speed	試験回数 Test #	回避可否 <sup>(*)</sup> Collision Avoided?(*)	初期速度 Initial speed	衝突速度 Speed at collision	速度低減量 Velocity reduction amount	速度低減率 Velocity reduction rate	速度低減率 中央値 Velocity reduction rate median
45 km/h	1回目 1st	○	45.2	0.0	45.2	1.00	1.00
	2回目 2nd	○	45.3	0.0	45.3	1.00	
	3回目 3rd						

○ラップ率 75%

Wrap rate 75%

(a) (b) (c)=(a)-(b) (d)=(c)/(a)

車速条件 Vehicle Speed	試験回数 Test #	回避可否 <sup>(*)</sup> Collision Avoided?(*)	初期速度 Initial speed	衝突速度 Speed at collision	速度低減量 Velocity reduction amount	速度低減率 Velocity reduction rate	速度低減率 中央値 Velocity reduction rate median
45 km/h	1回目 1st	P					1.00
	2回目 2nd						
	3回目 3rd						

○歩行速度 8km/h

Pedestrian speed 8km/h

(a) (b) (c)=(a)-(b) (d)=(c)/(a)

車速条件 Vehicle Speed	試験回数 Test #	回避可否 <sup>(*)</sup> Collision Avoided?(*)	初期速度 Initial speed	衝突速度 Speed at collision	速度低減量 Velocity reduction amount	速度低減率 Velocity reduction rate	速度低減率 中央値 Velocity reduction rate median
45 km/h	1回目 1st	○	45.3	0.0	45.3	1.00	1.00
	2回目 2nd	○	45.3	0.0	45.3	1.00	
	3回目 3rd						

(\*) ○: 衝突回避 Collision avoided、P: パス(回避扱い) Passed (deemed avoided)、

△: 速度軽減 Speed reduced、×: 不動作 No activation、-: 未実施 Not implemented

(6) 部分評価試験: CPFシナリオのFCWS試験

Partial evaluation test: CPF scenario FCWS test

○ラップ率 25%

Wrap rate 25%

(a) (b) (c)=(a)-(b) (d)=(c)/(a)

車速条件 Vehicle Speed	試験回数 Test #	回避可否 <sup>(*)</sup> Collision Avoided?(*)	初期速度 Initial speed	衝突速度 Speed at collision	速度低減量 Velocity reduction amount	速度低減率 Velocity reduction rate	速度低減率 中央値 Velocity reduction rate median
45 km/h	1回目 1st	○	45.2	0.0	45.2	1.00	1.00
	2回目 2nd	○	45.3	0.0	45.3	1.00	
	3回目 3rd						

○ラップ率 75%

Wrap rate 75%

(a) (b) (c)=(a)-(b) (d)=(c)/(a)

車速条件 Vehicle Speed	試験回数 Test #	回避可否 <sup>(*)</sup> Collision Avoided?(*)	初期速度 Initial speed	衝突速度 Speed at collision	速度低減量 Velocity reduction amount	速度低減率 Velocity reduction rate	速度低減率 中央値 Velocity reduction rate median
45 km/h	1回目 1st	P					1.00
	2回目 2nd						
	3回目 3rd						

○歩行速度 8km/h

Pedestrian speed 8km/h

(a) (b) (c)=(a)-(b) (d)=(c)/(a)

車速条件 Vehicle Speed	試験回数 Test #	回避可否 <sup>(*)</sup> Collision Avoided?(*)	初期速度 Initial speed	衝突速度 Speed at collision	速度低減量 Velocity reduction amount	速度低減率 Velocity reduction rate	速度低減率 中央値 Velocity reduction rate median
45 km/h	1回目 1st	○	45.3	0.0	45.3	1.00	1.00
	2回目 2nd	○	45.3	0.0	45.3	1.00	
	3回目 3rd						

(\*) ○: 衝突回避 Collision avoided、P: パス(回避扱い) Passed (deemed avoided)、

△: 速度軽減 Speed reduced、×: 不動作 No activation、-: 未実施 Not implemented

## 車線逸脱抑制装置等性能試験結果

### Test results of Lane Departure Prevention system etc. performance test

試験車名 Test Vehicle	トヨタ(TOYOTA) ヤリス(YARIS) X
試験車型式 Type	6AA-MXPH10
車台番号 Frame number	MXPH10-2026787
試験番号 Test number	NASVA2020-02501
試験時重量 Test vehicle weight	1184.0kg
タイヤサイズ Tire	185/60R15 84H
装置機能 Equipped systems	LDP機能・LDWS LDP & LDWS
手動復帰型装置の有無 Manual reset device?	無 (Not provided)
試験車速 Test vehicle speed	60km/h・70km/h
警報提示方法(LDWS) LDWS Prompting method	聴覚方式・視覚方式 Audio & Visual
逸脱方向の区別 Departure direction alert	区別なし NA

試験条件 Testing conditions		装置機能 Equipped Systems		評価点 Evaluation score			合計点 Overall points
		LDP/LKA	LDWS	LDP/LKA	LDWS	小計 Subtotal	
基本試験 Standard test	BL60	0.5m以下 Less than 0.5m	判定なし No judgment	4.00	評価なし No evaluation	4.00	16.0 / 16 Level 5 / 5
	BL70	0.5m以下 Less than 0.5m	判定なし No judgment	4.00	評価なし No evaluation	4.00	
	BR60	0.5m以下 Less than 0.5m	判定なし No judgment	4.00	評価なし No evaluation	4.00	
	BR70	0.5m以下 Less than 0.5m	判定なし No judgment	4.00	評価なし No evaluation	4.00	
手動復帰型装置試験 Manual reset device test	EL70	機能なし Not provided		評価なし No evaluation		評価なし No evaluation	
	ER70	機能なし Not provided		評価なし No evaluation		評価なし No evaluation	

装置機能の結果 Evaluation scores of the device	LDP/LKA	機能なし Not provided	当該機能がない装置の場合 For devices without this function
		0.5m以下 Less than 0.5m	逸脱量の評価値が0.5m以下であった場合 If the evaluation score is less than 0.5m
		0.5m超1.0m以下 Between over 0.5m and 1.0m or less	逸脱量の評価値が0.5mを超えかつ1.0m以下であった場合 If the evaluation score is between over 0.5m and 1.0m or less
		1.0m超 Over 1.0m	逸脱量の評価値が1.0mを超えた場合 If the evaluation score is over 1.0m
LDWS	機能なし Not provided	当該機能がない装置の場合 For devices without this function	
	適合 Conformed	LDWS適合判定が“適合”であった場合 If the LDWS is judged “conformed”	
	不適合 Not conformed	LDWS適合判定が“不適合”であった場合 If the LDWS is judged “Not conformed”	
	判定なし No judgment	基本試験のLDP/LKAの結果が“0.5m以下”であったためLDWSの判定を行わなかった場合 If the evaluation score for LDP and LKA Functions in standard tests was less than 0.5m and the LDW function was not judged.	
評価点の結果表示 Result display of evaluation points	LDP/LKA	0.00～4.00	評価点 Evaluation score
		評価なし No evaluation	基本試験のLDP機能/LKA機能の結果が“0.5m以下”であったため評価を行わなかった場合(手動復帰型装置試験のみ) If the evaluation score for LDP and LKA Functions in standard tests was less than 0.5m and the evaluation was not performed.(Manual reset type device test only)
	LDWS	0.00～4.00	評価点 Evaluation score
		評価なし No evaluation	基本試験のLDP機能/LKA機能の結果が“0.5m以下”であったため評価を行わなかった場合 If the evaluation score for LDP and LKA Functions in standard tests was less than 0.5m and the evaluation was not performed

※なお、LDWSにおいて、1つのみの(触覚又は聴覚によるものに限る。)の警報方法にあつては、逸脱方向が明確に分かるものは上の評価点を与えるものとし、それ以外のものは二分の一を評価点とする。  
Further, if there is only one type of warning device (limited to tactile or audio), when the deviation direction is easy to confirm, the above shall be the evaluation score; Otherwise, the above divided by 2 shall be the evaluation score.

車線逸脱抑制装置等性能試験結果 Test results of Lane Departure Prevention system etc. performance test

装置機能: LDP機能・LDWS  
System functions: LDP & LDWS

条件識別: 基本試験(60km/h)  
Conditions identified: Standard test (60km/h)

		左逸脱 Left departure			右逸脱 Right departure		
試験回数 Test #		1	2	3	1	2	3
ペダルストローク(%) Pedal stroke (%)	最大 Max	29	29		28	28	
	最小 Min	24	23		21	22	
走行速度(km/h) Running speed (km/h)	最大 Max	61.8	62.0		61.8	62.2	
	最小 Min	61.2	61.6		61.3	61.6	
最大ヨーレート (deg/s) Max. Yaw rate (deg/s)		0.83	0.90		0.79	0.97	
操舵終了タイミング (sec) End steering timing (sec)		2.25	1.61		1.95	2.25	
操舵終了位置 (m) End steering position (m)		-0.56	-0.69		-0.61	-0.61	
逸脱速度(m/s) Departure rate (m/s)	操舵終了時 End steering time	0.27	0.22		0.21	0.21	
	操舵終了直後 Immediately after end steering time	0.26	0.22		0.22	0.22	
	最大 Maximum	0.27	0.28		0.25	0.24	
操舵角速度(deg/s) Steering angle rate (deg/s)	操舵終了時まで Until end steering time	7.3	8.9		6.5	9.3	
	操舵終了位置+0.10mまで End steering position up to +0.10m	10.3	4.0		5.3	5.6	
最大逸脱量 (m) Maximum departure amount (m)		0.02	-0.02		0.03	0.03	
警報提示位置 (m) Warning system position (m)		-	-		-	-	
逸脱量の評価値 (m) Departure amount's evaluation value (m)		0.02			0.03		
LDWS適合判定(適合/不適合) LDWS compatibility assessment (Compatible/Incompatible)					-		

【備考】[Notes]



車線逸脱抑制装置等性能試験結果 Test results of Lane Departure Prevention system etc. performance test

装置機能: LDP機能・LDWS  
System functions: LDP & LDWS

条件識別: 基本試験(70km/h)  
Conditions identified: Standard test (70km/h)

		左逸脱 Left departure			右逸脱 Right departure		
試験回数 Test #		1	2	3	1	2	3
ペダルストローク(%) Pedal stroke (%)	最大 Max	30	30		29	30	
	最小 Min	24	24		22	22	
走行速度(km/h) Running speed (km/h)	最大 Max	71.1	71.4		72.1	71.8	
	最小 Min	70.6	70.9		71.6	71.3	
最大ヨーレート (deg/s) Max. Yaw rate (deg/s)		0.74	0.90		0.80	0.86	
操舵終了タイミング (sec) End steering timing (sec)		1.56	1.66		1.81	1.91	
操舵終了位置 (m) End steering position (m)		-0.69	-0.61		-0.74	-0.78	
逸脱速度(m/s) Departure rate (m/s)	操舵終了時 End steering time	0.17	0.24		0.23	0.21	
	操舵終了直後 Immediately after end steering time	0.18	0.24		0.24	0.21	
	最大 Maximum	0.25	0.26		0.30	0.25	
操舵角速度(deg/s) Steering angle rate (deg/s)	操舵終了時まで Until End Steering Time	7.2	11.7		9.7	6.7	
	操舵終了位置+0.10mまで End Steering Position up to +0.10m	8.0	10.8		3.7	6.0	
最大逸脱量 (m) Maximum departure amount (m)		-0.03	0.03		0.04	-0.01	
警報提示位置 (m) Warning system position (m)		-	-		-	-	
逸脱量の評価値 (m) Departure amount's evaluation value (m)		0.03			0.04		
LDWS適合判定(適合/不適合) LDWS compatibility assessment (Compatible/Incompatible)		-			-		

【備考】[Notes]

## 後方視界情報提供装置試験結果

### Test results of Rearview monitor system performance test

試験車名 Test Vehicle	トヨタ(TOYOTA) ヤリス(YARIS) X
試験車型式 Type	6AA-MXPH10
車台番号 Frame number	MXPH10-2026787
試験時重量 Test vehicle weight	1075kg
タイヤサイズ Tire	185/60R15
カメラ個数 Number of rear view cameras	1
カメラ位置 Position of rear view cameras	後ナンバープレート上 Above the rear license plate
情報表示方法 Information display unit	カーナビゲーションモニター Car navigation monitor

試験 Test	視対象物位置 Visual object position	情報表示方法 Information display method	表示エリア Display area	表示大きさ Display size
近接視界 Proximity field of vision	A	センターコンソール、NAVI画面、バックビュー Center console, Car navigation monitor, back view	○	
	B	センターコンソール、NAVI画面、バックビュー Center console, Car navigation monitor, back view	○	
	C	センターコンソール、NAVI画面、バックビュー Center console, Car navigation monitor, back view	○	
近傍視界 Adjacent field of vision	D	センターコンソール、NAVI画面、バックビュー Center console, Car navigation monitor, back view	○	
	E	センターコンソール、NAVI画面、バックビュー Center console, Car navigation monitor, back view	○	
遠方視界 Distant field of vision	F	センターコンソール、NAVI画面、バックビュー Center console, Car navigation monitor, back view	○	○
	G	センターコンソール、NAVI画面、バックビュー Center console, Car navigation monitor, back view	○	○
	H	センターコンソール、NAVI画面、バックビュー Center console, Car navigation monitor, back view	○	○

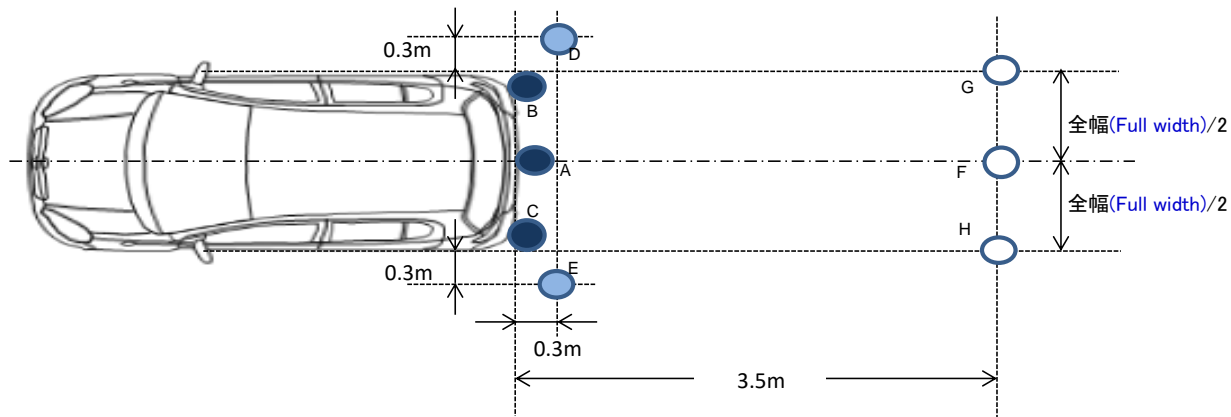

評価点 Evaluation score	6.0 / 6 Level 5 / 5
-------------------------	------------------------

- : 近接エリア評価視対象物(A,B,C)  
Visual object installation positions of proximity field of vision measurement (A,B,C)
- : 近傍エリア評価視対象物(D,E)  
Visual object installation positions for adjacent field of vision measurement (D,E)
- : 遠方エリア評価視対象物(F,G,H)  
Visual object installation positions for distant field of vision measurement (F,G,H)

近接視界 Proximity field of vision



遠方視界 Distant field of vision



近傍視界 Adjacent field of vision



## 高機能前照灯装備確認結果

### Check results of High-performance headlamp function and equipment

試験車名 Test Vehicle	トヨタ (TOYOTA) ヤリス (YARIS) X
試験車型式 Type	5BA-KSP210

装備装置 Installed device	自動防眩型前照灯 Automatic anti-glare type	自動切替型前照灯 Automatic switching type	左記以外の装置 Equipment other than those on the left
装備装置の有無 Presence of Installed device	無 (Not provided)	有 (Provided)	無 (Not provided)
作動開始速度 Start speed	-	30 km/h	-
作動終了速度 Operation end speed	-	-	-
評価点 Evaluation score	-	1.4	-

合計点 Overall points	1.4 / 5 Level 4 / 5
-----------------------	------------------------

ペダル踏み間違い時加速抑制装置性能試験結果

Test results of Equipment designed to curb acceleration in the event of peddle misapplication

試験車名 Test Vehicle	トヨタ(TOYOTA) ヤリス(YARIS) X
試験車型式 Type	6AA-MXPH10
車台番号 Frame number	MXPH10-2026787
試験番号 Test number	NASVA2020-02431
試験時重量 Test vehicle	1275.0kg
センサー方式:前方 Sensor system:Front	超音波 Ultrasonic
センサー方式:後方 Sensor system:Back	超音波 Ultrasonic
タイヤサイズ Tire	185/60R15 84H

試験 Test	試験走行開始位置 Test starting position	速度変化率 Speed change rate	評価点 Evaluation score
前進(Fon)	1.0m	1.0	1.0
後進(Ron)	1.0m	1.0	1.0

合計点 Overall points	2.0 / 2 Level 5 / 5
-----------------------	------------------------

評価点 Evaluation score		速度変化率 Speed change rate		
		1.0以上 1.0 or more	0.1以上1.0未満 0.1 or more and less than 1.0	0.1未満 Less than 0.1
試験走行 開始位置 Test starting position	1.0m	1.0	0.6	0.0
	0.9m	0.9	0.5	0.0
	0.8m	0.8	0.4	0.0

ペダル踏み間違い時加速抑制装置試験結果 Test results of Equipment designed to curb acceleration in the event of peddle misapplication

試験走行開始位置 前進: Test starting position Front:	1.0m	後進: Back:	1.0m
---	------	--------------	------

		最大横ずれ量 [m] Maximum lateral displacement [m]	ブレーキオフ時位置 [m] Position at time of brake off [m]	アクセルオン時速度 [km/h] Speed at time of acceleration [km/h]	アクセル踏み込み時間 [s] Accelerator depression time [s]	衝突速度 [km/h] Speed at collision [km/h]	衝突速度の中央値 Median of speed at collision	速度変化率 Speed change rate	回避可否 Avoidance
Foff	1回目 1st						-		
	2回目 2nd								
	3回目 3rd								
Fon	1回目 1st	0.01	1.01	0.0	0.16	0.0	0.0	1.0	○
	2回目 2nd								
	3回目 3rd								
Roff	1回目 1st						-		
	2回目 2nd								
	3回目 3rd								
Ron	1回目 1st	0.00	1.01	0.0	0.16	0.0	0.0	1.0	○
	2回目 2nd								
	3回目 3rd								

## 事故自動緊急通報装置装備確認結果

### Check results of Automatic Accident Emergency Call System

試験車名 Test Vehicle	トヨタ (TOYOTA) ヤリス (YARIS) X
試験車型式 Type	5BA-KSP210

装備装置 Installed device	先進型 Advanced type
評価点 Evaluation score	8

合計点 Overall points	8.0 / 8
-----------------------	---------