

This is a translation to English for reference purpose of JNCAP test method which is originally prescribed in Japanese language.
Please be sure to refer to the Japanese test method if you need to be precisely correct.

FRONTAL COLLISION SAFETY PERFORMANCE TEST METHOD

Created: April 1, 1995

Revised: March 20, 2018

March 24, 2017

1. Effective Dates

This test method will go into effect on April 1, 1995. However, the regulations revised on March 20, 2018 will go into effect beginning April 1, 2018.

2. Scope of Application

This test procedure applies exclusively to the "full wrap frontal collision safety performance" of passenger vehicles with 9 occupants or less and commercial vehicles with a gross vehicle mass of 2.8 tons or less conducted by the National Agency for Automotive Safety and Victims' Aid (hereinafter referred to as "NASVA") in the new car assessment program information supply project.

3. Definition of Terms

The terminology within this test method are defined as follows.

- (1) **"Barrier"**: The wall surface with which the test automobiles will collide.
- (2) **"Dummy"**: The anatomical models of adult men and women that ride in the test vehicle. In this test this refers to the Hybrid III Dummy Male 50th Percentile (CFR (United States Code of Federal Regulations) Title, Part, subpart E) and Hybrid III Dummy Female 5th Percentile (CFR (United States Code of Federal Regulations) Title 49, Part 572, subpart O) respectively.
- (3) **"HIC (Head Injury Criterion) "**: An index showing the degree of injury to the dummy's head.
- (4) **"Chest resultant acceleration"**: The resultant acceleration that occurs in the chest of a dummy at the time of impact.
- (5) **"Femur load"**: The load placed upon the portions of the dummy corresponding to the right and left femurs in the axial direction of the femurs at the time of impact.
- (6) **"NIC (Neck Injury Criterion) "**: Criterion for neck injuries
- (7) **"ThCC (Thorax Compression Criterion) "**: Criterion for thorax compression
- (8) **"TCFC (Tibia Compressive Force Criterion) "**: Criterion for tibia compressive force
- (9) **"TI (Tibia Index) "**: Tibia index
- (10) **"Designed hip point"**: The standard point determined regarding each seat according to protocol stipulated in an attached document (Attachment 2).

- (11) **"Hip point"**: A dummy's hip point in a test automobile as specified by the automobile manufacturer.
- (12) **"Ilium load"**: The load placed upon the portions of a dummy corresponding with the right and left iliac pelvic region
- (13) **"Slippage of lap belt from the pelvic region"**: A phenomenon in which a lap belt slips from the pelvic region of a dummy and is no longer able to provide proper pelvic restraint.

4. Test Environment

4.1 Condition of Test Vehicles

4.1.1 Provision of Data from Manufacturers

Automobile manufacturers shall provide the following data needed for test preparations to NASVA.

- (1) Appendix 1
- (2) Items for special confirmation regarding test preparations (the vehicle model along with items for confirmation concerning test preparations unique to certain vehicle models including the one in question).

4.1.2 Test Automobile Mass

- (1) The mass of the test automobile shall be adjusted to within the range of 100 to 101 percent of the mass when stored* without the dummies in the driver or passenger seats (referring to the seat next to the side of the automobile among those parallel to the driver seat, the same shall apply below), with the reduced mass of the measuring equipment (40kg) added.

However, this shall not apply to instances where the mass cannot be adjusted to within this range even by removing parts that have no chance of influencing test results. Furthermore, testing of automobiles equipped with spare tires and tools may be conducted with these items attached to the vehicle.

* Mass when stored: After the testing laboratory has received the test vehicle, its fuel tank shall be emptied, with all fluids aside from fuel filled to the maximum specified range and weights of a mass corresponding to 100% of the fuel tank capacity,(see Appendix 1, paragraph 3) (gasoline automobiles: fuel tank capacity x 0.745g/ml, diesel automobiles: fuel tank capacity x 0.840g/ml) before mass is measured. The automobile manufacturer may specify the location where the weights are loaded, with the premise that the position of the weights be equivalent to the upper side of the fuel tank location.

- (2) In regards to parts among installed components that have no influence on test results, the parts in question may be removed.

[Examples of parts that have no influence on test results]

Rear seats, rear bumper, rear carriage trim, rear side windows, rear windshield, rear seat carpeting, trunk door, rear doors, muffler, lighting units, and other items installed to the rear of where the driver seat shoulder harness is affixed.

4.1.3 Vehicle Attitude

The vehicle attitude of the test automobile shall, in a state with dummies onboard, be $\pm 3^\circ$ in the

front-back direction and $\pm 1^\circ$ in the left-right direction in regards to the vehicle attitude specified by the automobile manufacturer.

4.1.4 Test Automobile Fluids

- (1) Oil and similar fluids may be removed.
- (2) Battery liquid must be removed (excluding instances where there is no concern of battery liquid leaking during collisions such as when the battery is located in the rear trunk). However, in cases where the test vehicle is equipped with electrical restraint devices such as airbags and seatbelts with pretensioner structures, a replacement power source may be installed as necessary in a location that will not influence test results with consideration of having said restraint devices operate properly.
- (3) The fuel tank must be filled with colored water equivalent to the fuel mass when the fuel tank is filled to over 90% capacity.

4.1.5 Seat Adjustment

4.1.5.1 Driver Seat

The driver seat shall be set to a position stipulated within (1) and (5) below. Details on each adjusting device, including compound type adjusting devices, shall be indicated in a separate document.

- (1) In cases where the driver seat can be adjusted in a front-back direction using seat rails, the seat shall be adjusted to the midpoint in the front-back direction. However, if the seat cannot be adjusted to the midpoint in the front-back direction, the seat shall be adjusted to a point as close as possible to the rear of the midpoint in the front-back direction. However, in the event that the dummy cannot be loaded properly, and the designed hip point of the driver seat falls within the following equations (When the coordinates indicating the location of the designed hip point on the seat surface of Diagram 1 (x_1, z_1) are to the left of line A), the front seats may be adjusted until dummies can be adequately put onboard* so that respective adjustments can be made so that the coordinates indicating the location of the designed hip point on the seat surface of Diagram 1 are to the right of line A and the driver seat is in a location as near as possible to line A.

$$X < \frac{1670 - Z}{1.94}$$

In this case,

X passes through the designed center of the acceleration pedal surface, with the horizontal front-back direction distance (unit: mm) in a horizontal line running orthogonally to the center plane of the carriage until the designed hip point.

Z passes through the designed center of the acceleration pedal surface, with the vertical left-right direction distance (unit: mm) in a vertical line running orthogonally to the center plane of the carriage until the designed hip point.

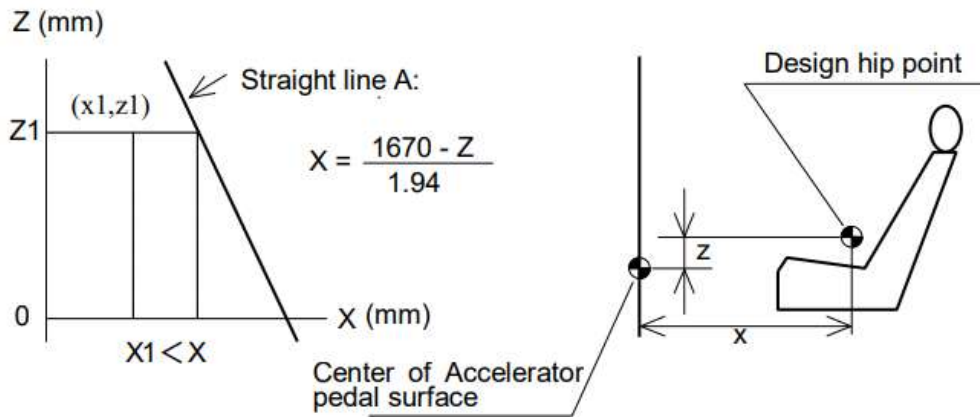

Diagram 1

*“Until dummies can be adequately put onboard” refers to meeting the following requirements.

- ① The head angle must be within $\pm 0.5^\circ$ horizontally.
- ② The pelvic angle must be within $22.5^\circ \pm 2.5^\circ$ horizontally.
- ③ The legs must be under 20mm of acceleration pedal stepping quantity.
- ④ Space between the femoral region and the steering wheel must be at least 20mm, and space between the femoral region and the seat surface must be under 30mm.
- ⑤ With the knee region, the space between the lower body and instrument panel and steering column cover must be at least 10mm.

(2) In cases where the driver seat can be adjusted in the up-down direction (excluding those instances where the angle of the seat floor, seat surface, and seat back all change simultaneously), the seat shall be adjusted to the lowest up-down direction position possible.

(3) In cases where seat back angle of the driver seat can be adjusted, the seat shall be adjusted to the standard angle as designed. Furthermore, if the hip support portion of the seat back can be adjusted, this portion shall be adjusted to the lowest possible position.

(4) In cases where the headrest of the driver seat can be adjusted in the up-down direction, the headrest shall be locked in at the highest possible position in the up-down direction.

(5) In cases where the driver seat has adjustment devices other than those mentioned in (1) to (4), such devices shall be adjusted to the standard position or standard angle as designed.

4.1.5.2 Passenger Seats

The driver seat shall be set to a position stipulated within (1) and (5) below. Details on each adjusting device, including compound type adjusting devices, shall be indicated in a separate document.

(1) The front passenger seat shall be adjusted at standard position as designed, which is forward from the mid-point, if adjustable in front-back direction by the seat rail. However, when the design standard position is not specified, it is made as close as possible to the further intermediate position between the front most position and the intermediate position (within 25% from the front most position of the adjustable range). If it is not possible to adjust to the intermediate position further between the foremost position and the intermediate position, it is adjusted to an adjustable

position that is rearward of this position and closest thereto. Also, the distance between the lower leg of the dummy and the instrument panel must be adjusted to a position where it can be secured by at least 10 mm.

- (2) The front passenger seat shall be adjusted at standard position as designed if adjustable in up-down direction (excluding adjusters that also affect the angles of the seat lower, the seat surface and the seat back at the same time).
- (3) In cases where seat back angle of the passenger seat can be adjusted, the seat shall be adjusted to the standard angle as designed. However, it shall be re-adjusted if the dummy's head angle cannot be adjusted within the range of ± 0.5 degrees in a horizontal direction.
- (4) In cases where the headrest of the passenger seat can be adjusted in the up-down direction, the headrest shall be locked in at the highest possible position in the up-down direction.
- (5) In cases where the passenger seat has adjustment devices other than those mentioned in (1) to (4), such devices shall be adjusted to the standard position or standard angle as designed.

4.1.5.3 Seats other than the Driver and Passenger Seats

Seats other than the driver seat and passenger seat (referred to hereafter as "front seats") shall be adjusted to the standard position and angle as designed.

4.1.6 Adjustment of the Steering System

- (1) In cases where the steering system can be adjusted upwards or downwards, it should be in a position that is in the geometrical center of the adjustable range when driving. However, in cases where the steering system cannot be adjusted into a central position, it must be adjusted to the closest possible position lower than a central position.
- (2) In cases where the steering system can be adjusted forwards or backwards, it should be in a position that is in the geometrical center of the adjustable range when driving. However, in cases where the steering system cannot be adjusted into a central position, it must be adjusted to the closest possible position to the rear of a central position.

4.1.7 Adjustment of the Seat Belt Shoulder Harness Mounting

In the event that the position of the seat belt shoulder harness mounting is adjustable, it should be placed in the standard position as designed.

4.1.8 Other Vehicle Conditions

4.1.8.1 Ignition

The motor of the test automobile should be in a stopped state. However, the ignition switch should be in the ON position.

If the test automobile is equipped with electrical restraint devices such as airbags and seat belts with pre-tensioner structures, it should be confirmed that such devices will operate properly with warning lamps when the ignition switch is put in the ON position. In regards to vehicles equipped with electric motors, the motor power supply circuit may be quarantined if the structure is such that it will not influence these devices upon consultation with the automobile manufacturer.

4.1.8.2 Side Windows and Doors

All side windows of the test vehicle that can be opened, should be opened (excluding those to the

rear of the driver seat).

Doors should be properly shut. However, they shall not be locked.

Furthermore, automobiles equipped with systems that lock doors in response to vehicle speed or increases in vehicle speed/engine rotations will have said systems disabled in cases where a means of setting/disabling the system is noted in the user's manual, and if it is possible to easily perform such operations without the use of tools.

4.1.8.3 Roof

Automobiles possessing a removable roof should have said roof attached.

Automobiles with a sunroof should have the sunroof closed.

Automobiles with canopy should have the roof in a closed state.

4.1.8.4 Drive Shaft, Shift Position, and Parking Brake Devices

Automobiles with a selectable drive shaft should have the drive shaft for normal use selected.

Shift position should be in neutral.

Parking brake devices must be released.

4.1.8.5 Tires

The air pressure in tires must be that which is noted on the specification sheet.

4.1.8.6 Others

(1) Attachment of strobes

Test automobiles must have strobes attached to indicate the moment of impact in order to isolate the instant collision begins in footage captured using a high-speed photographing apparatus. However, this shall not apply to cases where said strobes are attached in aboveground facilities within the visual field of the high-speed photographing apparatus.

(2) Modification of the test automobile

There must be no modification of a test automobile's structure or systems that are to the front of the driver seat.

However, this shall not apply to cases such as where modification is necessary to the towing of the test vehicle and will not influence test results, strobes and the like attached to indicate moment of impact, or equipment needed to measure the speed of the test automobile will be attached.

Modifications necessary to the towing of the test vehicle can be performed with hooks, lower suspension arms, stabilizers, tension arms, front cross members, and floor cross members.

(3) Affixing target marks

Marks (referred to hereafter as "target marks") shall be affixed to test automobiles in locations deformed by testing in order to ascertain the state of deformation caused by testing.

When affixing target marks the position and spacing of target marks must be recorded in the datasheet (standard locations being the vehicle's keyholes and side sills, with the size recorded).

(4) Coloration of the cabin interior

In cases where the interior of the cabin is colored in order to easily identify the impact positions of dummies and the cabin interior, the interior must be colored in a hue different than that of the chalk liquid applied to the dummies.

(5) Adjustment of vehicle height

Test automobiles must have a general posture that meets the requirements noted in items 4.1.3. Vehicles equipped with suspension that adjusts the minimum under clearance will be tested under the normal usage conditions at 55km/h stipulated by the automobile manufacturer.

(6) Collision position confirmation lines

The front portion of the test automobile must have lines drawn on the portion indicating the central plane of the vehicle in order to confirm collision position with the center of the barrier.

4.1.9 Dummies and Seat Belts

4.1.9.1 Loading the Dummies

The driver seat and passenger seat dummies, shall be in the test automobile in a state described in sections 4.1.5 to 4.1.7 of the enclosed document 1 part 1 and part 2 respectively. However, in cases where it is necessary in order to place the dummies onboard as stipulated, the position of the seats may be adjusted and steering parts removed. After the dummies are loaded onboard as specified, the positions of the seats should be placed in the state described in sections 4.1.5 to 4.1.7, and any removed parts restored to their proper state.

Seat adjustments that can be performed as part of the above provision are up-down positioning of the seat, seat back angle, seat back hip support position, angle at which seat lower is attached, up-down and front-back positioning of the headrest, as well as axial direction and angle of the steering column. Parts that may be removed are the cover of the seat position and angle adjusting device (up-down positioning of the seat, seat back angle, seat back hip support position, angle at which seat lower is attached), the headrest, steering wheel, doors, tops for vehicles with convertible and removable roofs.

4.1.9.2 Fastening of the Seatbelt

Once the dummies have been loaded into the front seats of the test vehicle, the seatbelt must be fastened in such a way that its position around the dummies is the standard position as designed. On such occasions any slackness of the seatbelt must be sufficiently removed. However, in instances where, there is a device for eliminating pressure on the passenger when the seatbelt is fastened, it shall be allowed to create the standard slackness in the shoulder harness as designed.

In adult male 50th percentile dummies it must be confirmed that the seatbelt set in the standard position as designed does not completely cover the adjustment hole in the dummy's chest portion. If the set seatbelt does completely cover the adjustment hole, repeatedly pull the harness in a horizontal direction so that it passes over the center of the dummy and release it so that it settles naturally on dummies chest four times. The result of this process shall be ① that the harness does not completely block the adjustment hole in the dummy's chest, and that position shall become the seatbelt position if all present agree upon it. If agreement cannot be reached about seatbelt position ①, the seatbelt will be reset to its standard position as designed once more with the harness moved to a position where it does not completely block the adjustment hole. Furthermore, if the harness is completely blocking the adjustment hole in the dummy's chest as a result of repeating ①, the seatbelt will be reset to its standard position as designed once more with the harness moved to a

position where it does not completely block the adjustment hole.

As for adult female 5th percentile dummies, confirm that the center of the harness passes between the breasts in a natural position like that assumed for normal use. In the event that it does not conform to this, the seatbelt will be set to the standard position as designed with the harness moved to the conforming position in order to gain the agreement of those present.

4.1.9.3 Measuring the Lead Amount of Seatbelt

The lead amount of the seatbelts of the driver and passenger seats is to be measured at the time of testing. If the seatbelts have pretensioners attached then the pull will be measured as well. However, this measurement may be omitted in the event that measurement proves too difficult.

A simple measurement method employing string is indicated in appendix 2.

4.1.9.4 Dummy Temperature Requirements

Dummies must be kept for at least 4 hours in a room with a steady temperature of 20-23°C up until immediately before testing in order to stabilize their temperature. Processes such as the loading of the dummies in the test vehicle may be conducted during this storage time. Furthermore, in cases where it proves unavoidable for preparing for implementing of testing, it is acceptable to store the dummies in an environment outside of the aforementioned controlled temperature for an accumulated time of no more than 10 minutes. The point of temperature measurement, if the dummies are in the cabin of the test automobile, shall be at a point equal to the height of the dummies in the driver and passenger seat's shoulders. If different, it shall be at a height equivalent to such.

4.1.9.5 Coloring of Dummies

In order to judge the secondary impacts of the head and knees, a chalk liquid paint shall be applied to the face, head, and legs of a dummy. Furthermore, in order to confirm the secondary impact to the chest of the driver seat dummy with the steering wheel, chalk liquid paint will be applied to, for the time being on a trial basis, to the bottom lower surface of the steering rim (For vehicles with a steering angle of over 32°).

No additional paint may be applied to areas other than those specified above.

4.1.10 Loading Electrical Measuring Equipment

4.1.10.1 Attaching Accelerometers

Accelerometers will be attached to the locations indicated below on the test automobile to measure acceleration during collision. However, in the event that attaching in the specified locations proves difficult, the locations may be changed based upon the decision of the testing laboratory.

- (1) Tunnel: 3 axis (front-back, left-right, and up-down directions)
- (2) Inside the vehicle's left side sill: 1 axis (front-back direction)
- (3) Inside the vehicle's right side sill: 1 axis (front-back direction)

These accelerometer positions will be listed by the testing laboratory and noted in Appendix 3.

4.1.10.2 Installation of Measuring Equipment

- (1) Measuring equipment is to be affixed securely in positions that will not be affected by deformations caused by collision tests on the test automobile. However, in the event that loading space cannot be procured within the vehicle, equipment may be loaded on external portions of the vehicle

recommended by the automobile manufacturer.

(2) Wiring connecting the measuring equipment affixed to the test automobile with the transducer (the equipment converting the measured physical quantities into electrical signals) shall be given enough slack that it does not affect behavior of dummies during collision tests.

4.2 Test Facilities

4.2.1 The Barrier

The barrier is to be made of reinforced concrete possessed of sufficient structure and mass to withstand the collision of the test automobile, with its front side being at least 1.5m tall and 3m wide, and perpendicular to the runway.

A plywood board of a thickness of 20 ± 2 mm shall be affixed to the front of the barrier during a collision test.

An iron plate may be placed in between the barrier and the plywood in order to protect the barrier.

4.2.2 The Runway

The runway must be an even, level, and dry road surface.

4.2.3 Towing Unit

The towing unit must be capable of bringing the coast traveling speed of an automobile with a mass of up to 2.8 tons to 55.0 ± 1 km/h to collide perpendicularly with the front surface of the barrier.

4.2.4 Lighting System

The lighting system must be capable of producing the amount of light needed for high-speed photography and must not cause halation.

4.2.5 High-speed Photographing Apparatus

The photographing speed of the high-speed photographing apparatus must be set to at least 500 frames/second. Furthermore, time interval of the time base signal (timing pulse) must be under 10ms.

It is acceptable to attach a deflection filter to the camera doing the filming in order to weaken unnecessary illumination or light.

4.2.6 Speed Measurement Device

The speed measurement device must be capable of measuring the time while the test automobile passes through the time measurement section in units of under 0.1ms.

In the event that speed converted from passage time is converted to units of km/h, it will be displayed up to 1 decimal place.

The speed measurement device must be set up so that it is capable of measuring the speed of the test automobile with 2m immediately preceding collision.

4.2.7 Temperature and Humidity Measuring Equipment

The temperature of a dummy before testing as stipulated in section 4.1.9.4 and the dummy's temperature and humidity during inspection must be recorded at intervals of within 1 minute by an automatic logger. The minimum scale for the thermometer should be 0.1°C , while the minimum scale for the hydrometer (relative hydrometer) should be 1%.

4.2.8 Electrical Measuring Equipment

The connected state of measuring equipment, including all devices that compose them and output

units (including analysis computers (measurement equipment in this state shall be referred to as “measurement channels”)) must conform to ISO 6487:2002*1.

(1) Measurement channels shall measure speed, load, momentum, and changes in position using the channel classes mentioned below.

① Collision tests will be composed of the following.

(a) Head acceleration shall be 1,000

(b) Neck load shall be 1,000.

(c) Neck momentum shall be 600.

(d) Chest acceleration shall be 180.

(e) Chest position change shall be 180 for adult male 50th percentile dummies and 600 for adult female 5th percentile dummies.

(f) Hip acceleration shall be 1000.

(g) Femoral load shall be 600.

(h) Change in knee position (adult male 50th percentile dummies only) shall be 180.

(i) Tibia load (adult male 50th percentile dummies only) shall be 600.

(j) Tibia momentum (adult male 50th percentile dummies only) shall be 600.

(k) Tibia load (adult female 5th percentile dummies only) shall be 180.

(l) Tibia momentum (adult female 5th percentile dummies only) shall be 1,000.

(m) Side sill acceleration shall be 60.

(n) Tunnel acceleration shall be 60.

② Dummy inspection shall be the following in addition to ①.

(a) Neck pendulum acceleration shall be 60 for adult male 50th percentile dummies and 180 for adult female 5th percentile dummies).

(b) Change in position of the neck rotation detector shall be 60.

(c) Chest impact element acceleration shall be 180.

(d) Knee impact element acceleration shall be 600.

(e) Leg impact element acceleration (adult male 50th percentile dummies only) shall be 600.

(2) If analog values are to be converted to digital values on measurement channels, the number of samples per second shall be over 8,000, and in collision tests, be of at least 8 times more than the channel class specified in ② for dummy inspections.

(3) HIC calculations shall be conducted with the sampling time as the lowest possible time interval (the time interval for data samples conducted under the aforementioned regulations). The range of this calculation shall be between the collision and 200 ms after the collision.

(4) Elimination of high frequency components (filter processing) according to the channel classes mentioned above shall be conducted before calculation of head resultant acceleration, chest resultant acceleration, and HIC.

4.2.9 Accelerometer, Load Indicator, Moment Detector, Dummy

4.2.9.1 Accelerometer, Load Indicator, Moment Detector used in Testing

*1 ISO 6487:2000 is considered as the same requirement

The measurement range of the Accelerometer, moment detector, and load indicator, shall as a general rule be the following.

- (1) The accelerometer attached to a dummy's head shall be from $-1,960\text{m/s}^2$ (-200G) to $+1,960\text{m/s}^2$ (+200G).
- (2) The load indicator attached to a dummy's neck shall be from -890daN (-907kgf) to $+890\text{daN}$ (+907kgf).
- (3) The moment detector attached to a dummy's neck shall be from -285Nm (-29kgfm) to $+285\text{Nm}$ (+29kgfm).
- (4) The accelerometer attached to a dummy's chest shall be from -980m/s^2 (-100G) to $+980\text{m/s}^2$ (+100G).
- (5) The load indicator attached to a dummy's ilium shall be from -890daN (-907kgf) to $+890\text{daN}$ (+907kgf).
- (6) The load indicator attached to a dummy's knee shall be from 0 to $1,960\text{daN}$ (2000kgf).
- (7) The accelerometer attached to the side sill shall be from $-1,960\text{m/s}^2$ (-200G) to $+980\text{m/s}^2$ (+200G).
- (8) The accelerometer attached to the tunnel shall be from $-1,960\text{m/s}^2$ (-200G) to $+1,960\text{m/s}^2$ (+200G).

4.2.9.2 The Dummies

- (1) The driver seat dummy shall be a Hybrid III Dummy Male 50th Percentile as specified in the CFR (United States Code of Federal Regulations) Title 49, Part 572, subpart E. The passenger seat dummy shall be a Hybrid III Dummy Female 5th Percentile as specified in the CFR (United States Code of Federal Regulations) Title 49, Part 572, subpart O respectively.
- (2) The characteristics of each part of the driver seat dummy shall conform to the inspections in Attachment 3-1. Furthermore, the characteristics of each part of the passenger seat dummy shall conform to the inspections in Attachment 3-2. For inspections on feet wearing shoes, in the event that adjustments to the characteristics of the footwear are necessary, insoles may be used.
- (3) Neck shields should be attached to the necks of dummies. The feet of dummies in the driver seat should be size 11XW shoes, with the shape size, and thickness of the shoe sole and heel conforming to US military regulation MIL-S-13192P (Amendment 1), with the weight being measured at $0.57\pm 0.1\text{kg}$. Furthermore, shoes on the feet of the passenger seat dummy should be size 7 1/2E shoes, with the shape size, and thickness of the shoe sole and heel conforming to US military regulation MIL-S-21711E and the weight being measured at $0.41\pm 0.09\text{kg}$. Dummies can wearing cotton short-sleeved shirts (or cotton sleeveless shirts) along with short pants.
- (4) When the joints of a dummy's limbs are fixed in place and its limbs and legs are levelled, they should be adjusted to an extent that they are capable of supporting their own weight.
- (5) A dummy's head should have a target mark affixed to it at a position that allows the camera photographing the dummy's movement to capture it in order to confirm the dummy's behavior during the impact test. Diagram 2 provides an example of this.

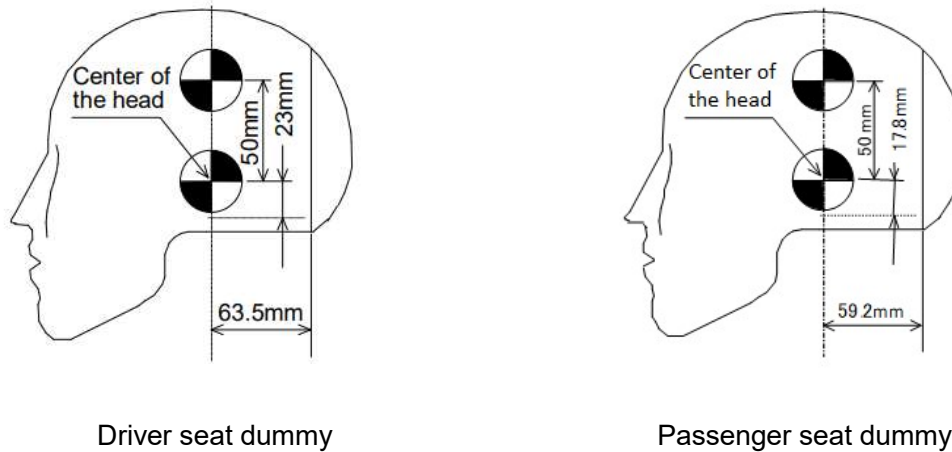

Diagram 2

4.2.9.3 Recording of Electrical Measurement Results onto Recording Medium

The recording of acceleration and load measurement results on to a recording medium should be at above channel class 1,000.

4.2.10 Three-dimensional Measurement Devices

The accuracy of three-dimensional measurement devices used to measure the vehicular dimensions of the test automobile, and measure the seated position of dummies along with the affixed position of seatbelts shall be under 0.5mm/m.

5. Test Method

The test automobile will travel at a speed of $55.0 \pm 1 \text{ km/h}$ and made to collide perpendicularly with the front of the barrier.

The draw speed of the equipment pulling the test automobile should be under $4.9 \text{ m/s}^2\{0.5G\}$, and the space between the center plane of the vehicle and the center plane of the barrier at the time of collision should be under 300mm.

6. Items to be Recorded and Measured

6.1 Pre-test Records

6.1.1 Checks and Records of the Received Vehicle

After the testing laboratory has received the test automobile and confirmed the items indicated below, said items are to be recorded in Appendix 4 as well as checked to ensure that they match the test automobile specifications indicated by NASVA.

- (1) Vehicle name, model, and classification division
- (2) Frame number
- (3) Car-body shape
- (4) Engine type
- (5) Drive system
- (6) Transmission type

- (7) Steering system type (wheel and steering column, existence of an adjustment system)
- (8) Seatbelt, winder, and fastener type (driver and passenger seats)
- (9) Existence of airbags (driver and passenger seats)
- (10) Seat type (driver and passenger seats, existence of adjustment systems)
- (11) Existence of air conditioning
- (12) Existence of power steering
- (13) Existence of vehicle speed sensitive door locks
- (14) Existence of ABS/traction control systems
- (15) Existence of a sunroof
- (16) Existence of foot rests

6.1.2 Recording of Dummy Inspection Results

- (1) The testing laboratory must record dummy inspection results.
- (2) Dummies are to be re-inspected after three tests are conducted. However, in the event that the injury value reaches or exceeds the normally acceptable limit (example: HIC 1,000), the parts of the dummy in question must be re-inspected. Furthermore, in the event that portions of a dummy are damaged in testing, the portions in question are to be exchanged for components that have undergone inspection.

6.1.3 Recording the Calibration of Measuring Instruments

- (1) Calibrations results of measuring instruments (measurement channels, including transducers) conducted before testing are to be recorded. The validated period of measuring instrument calibrations is 1 year, with operating results not called into question during this period. However, in the event that an abnormality is recognized, the instrument is to undergo recalibration on the spot.
- (2) A calibration signal generator (waveform generator) is to be used to verify whether or not injury values have been calculated correctly.

6.1.4 Recording of Pre-test Vehicular Dimension Measurement Results

Of the pre-test position of body components indicated below, cabin interior No 8, 9 and door vicinity No 7 are to be measured and recorded using a three-dimensional measuring device. In such cases, locations that will not be deformed by collision shall be selected for the standard measured vehicular dimension positions. Measurement of other locations may be entrusted to the manufacturer.

- (1) Points of measurement inside the cabin (examples)

Note) The lateral direction positions of locations No 4 to 7 are positions where the side of the driver seat is symmetrical on both sides of the vehicle, driver and passenger, to the center position of the brake pedal.

Position No.	Measuring Point	Position No.	Measuring
1	Instrument panel - right end	8	Steering column tip
2	Instrument panel - center	9	Brake pedal
3	Instrument panel – left end	10	Footrest
4	Driver seat side toe board	11	Driver seat side toe board A
5	Passenger seat side toe board	12	Passenger seat side toe board B
6	Driver seat side floor	13	Driver seat side floor A
7	Passenger seat side floor	14	Passenger seat side floor B

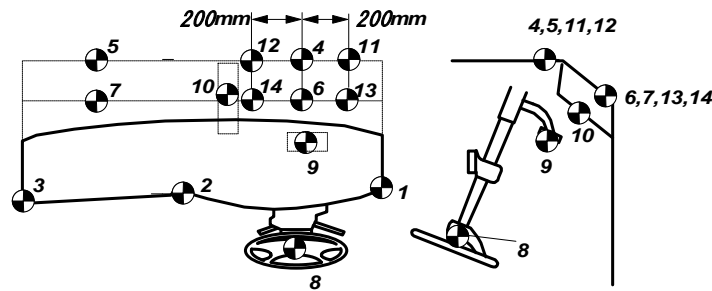

(2) Door vicinity measuring points (examples)

Position No	Measuring Point
1	A pillar upper end
2	B pillar upper end
3	Striker bolt
4	B pillar lower end
5	A pillar lower end
6	A pillar center
7	A pillar joint

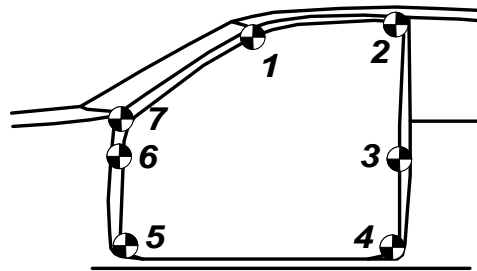

6.1.5 Recording of Dummy Seated Position Measurement Results

The seating position of the dummy placed in the vehicle according to the Paragraph 4.1.9.1 and the routing position of the seat belt fastened according to the Paragraph 4.1.9.2 shall be measured and recorded according to the section 13-1 of Appendix 1. Furthermore, photographs are to be taken of the fastened position of the seatbelts.

6.1.6 Recording of the Final Pre-test State of Vehicles

The following items are to be confirmed and recorded once preparation of a test automobile is completed according to Section 4.

- (1) Mass of the test automobile
- (2) Names and masse of parts removed, and mass after adjustment
- (3) Attitude of the test automobile (front-back and left-right direction inclinations)
- (4) Adjusted seat positions (driver seat and passenger seat)
- (5) Adjusted position of the steering system

- (6) Adjusted position of seatbelt fastening systems
- (7) Position of accelerometers attached to the vehicle body
- (8) Position of target marks affixed to the vehicle body
- (9) Standard position of vehicular dimensions

6.1.7 Recording of Dummy Temperature

- (1) The temperature of a dummy at the time soaking begins, ends, and during soaking is to be recorded.
- (2) The accumulated time when temperature requirements stipulated in Section 4.1.9.4 could not be maintained are to be recorded.

6.2 Records during testing

6.2.1 Recording of collision speed and collision position variance

The speed of the test automobile just before it collides with the barrier is to be measured and recorded. Furthermore, the divergence between the central plane of the vehicle and the central plane of the barrier at the time of collision are to be measured and recorded.

Just before collision is said to be the state when the test automobile is traveling by momentum within 2m in front of the barrier.

6.2.2 Recording of Electric Measurement Results from Dummy Parts, Vehicle Body Parts, and the Barrier.

The electrical measurement results of the accelerometers, load indicators, displacement gages, and moment sensors attached to the dummy parts, vehicle body parts, and the barrier listed below are to be recorded from 20ms preceding collision to 200ms following collision.

- (1) Driver seat dummy head front-back direction acceleration
- (2) Driver seat dummy head left-right direction acceleration
- (3) Driver seat dummy head up-down direction acceleration
- (4) Driver seat dummy neck front-back direction load
- (5) Driver seat dummy neck left-right direction load
- (6) Driver seat dummy neck up-down direction load
- (7) Driver seat dummy neck front-back direction moment
- (8) Driver seat dummy neck left-right direction moment
- (9) Driver seat dummy neck up-down direction moment
- (10) Driver seat dummy chest front-back direction acceleration
- (11) Driver seat dummy chest left-right direction acceleration
- (12) Driver seat dummy chest up-down direction acceleration
- (13) Driver seat dummy chest displacement
- (14) Driver seat dummy right femur load
- (15) Driver seat dummy left femur load
- (16) Driver seat dummy right knee displacement
- (17) Driver seat dummy left knee displacement
- (18) Driver seat dummy right upper tibia up-down direction load

- (19) Driver seat dummy right upper tibia front-back direction moment
- (20) Driver seat dummy right upper tibia up-down direction moment
- (21) Passenger seat dummy head front-back direction acceleration
- (22) Passenger seat dummy head left-right direction acceleration
- (23) Passenger seat dummy head up-down direction acceleration
- (24) Passenger seat dummy neck front-back direction load
- (25) Passenger seat dummy neck left-right direction load
- (26) Passenger seat dummy neck up-down direction load
- (27) Passenger seat dummy neck front-back direction moment
- (28) Passenger seat dummy neck left-right direction moment
- (29) Passenger seat dummy neck up-down direction moment
- (30) Passenger seat dummy chest front-back direction acceleration
- (31) Passenger seat dummy chest left-right direction acceleration
- (32) Passenger seat dummy chest up-down direction acceleration
- (33) Passenger seat dummy chest displacement
- (34) Passenger seat dummy right femur load
- (35) Passenger seat dummy left femur load
- (36) Passenger seat dummy right ilium front-back direction load
- (37) Passenger seat dummy right ilium front-back direction moment
- (38) Passenger seat dummy left ilium front-back direction load
- (39) Passenger seat dummy left ilium front-back direction moment
- (40) Passenger seat dummy pelvis front-back direction acceleration
- (41) Driver seat dummy right lower tibia up-down direction load
- (42) Driver seat dummy right lower tibia front-back direction moment
- (43) Driver seat dummy right lower tibia up-down direction moment
- (44) Driver seat dummy left upper tibia up-down direction load
- (45) Driver seat dummy left upper tibia front-back direction moment
- (46) Driver seat dummy left upper tibia left-right direction moment
- (47) Driver seat dummy left lower tibia up-down direction load
- (48) Driver seat dummy left lower tibia front-back direction moment
- (49) Driver seat dummy left upper tibia left-right direction moment
- (50) Passenger seat dummy pelvis up-down direction acceleration
- (51) Right side sill front-back direction acceleration
- (52) Left side sill front-back direction acceleration
- (53) Tunnel front-back direction acceleration
- (54) Tunnel left-right direction acceleration
- (55) Tunnel up-down direction acceleration

6.2.3 Recording of Damage Values

Dummy damage values are to be calculated and recorded using the methods indicate below from

the waveforms required in Section 6.2.2.

(1) Head damage value (HIC : Head Injury Criterion)

The maximum value of the value calculated according to the following formula using resultant dummy head acceleration is needed.

$$HIC = \left[\frac{1}{t_2 - t_1} \int_{t_1}^{t_2} \frac{a_R}{9.8} dt \right]^{2.5} (t_2 - t_1).$$

In this case,

a_R is the resultant acceleration of the head's front-back, left-right, and up-down direction acceleration (a_X a_Y a_Z) (unit: m/s)

$$a_R = \sqrt{a_X^2 + a_Y^2 + a_Z^2}$$

t_1 and t_2 are the discretionary times during collision (unit: s)

However, male 50th percentile dummies are $| t_2 - t_1 | \leq 0.036s$,

while female 5th percentile dummies are $| t_2 - t_1 | \leq 0.015s$

In regards to cases that are sharp waveforms recognized to have occurred due to secondary collisions of the head and knees on a resultant dummy head acceleration waveform chart and possess portions where the positive value of the rate of change in resultant acceleration is over 196m/s²/ms and the negative value is under -196m/s²/ms, portions of the waveform in question exceed the greater of the acceleration at the time where rate of change is the quickest, or greater than 196m/s²/ms in the vicinity of the time when the secondary collision begins, and the acceleration at the time where rate of change is the slowest, or lower than -196m/s²/ms in the vicinity of the time when the secondary collision ends, is to discarded during calculation. The specific procedure of discarding this value is described below.

- ① Confirm that secondary collision has occurred by either the presence of liquid, such as the chalk liquid applied to dummies pre-test, on the knees of the dummy, or using images taken by high-speed photography.
- ② In regards to the resultant dummy head acceleration waveform chart, confirm that waveforms that are presumed to have occurred due to secondary collision include portions where the rate of change in resultant acceleration is over 196m/s²/ms and the negative value is under -196m/s²/ms.
- ③ Resultant acceleration may be discarded using the procedures described below, only in those instances where secondary collision has been confirmed following the stipulations of ① and the resultant head acceleration that occurred due to said collision meets the requirements of ②.
 - a) The time, resultant acceleration, and rate of change in resultant acceleration between the time near the moment secondary collision begins and time near the moment secondary collision ends take from the resultant head acceleration data are to be output as numerical values.
 - b) Among the output numerical values, the acceleration where the quickest rate of change in

resultant acceleration is greater than $196\text{m/s}^2/\text{ms}$ are to be compared with the acceleration where the slowest rate of change in resultant acceleration is lower than $-196\text{m/s}^2/\text{ms}$, with the larger of these accelerations becoming the “discarded acceleration”.

c) In regards to accelerations between the time where the quickest rate of change in resultant acceleration is greater than $196\text{m/s}^2/\text{ms}$ and the time where the slowest rate of change in resultant acceleration is lower than $-196\text{m/s}^2/\text{ms}$, said acceleration will replace the value of the “discarded acceleration” only in cases where it is greater than the “discarded acceleration”.

(2) NIC : Neck Injury Criterion

- NIC is determined by the compressive force in the axial direction where the neck and the head of the dummy are connected, tension in the axial direction, fore-and-aft shear strength, and the period of time (ms) for which these forces continue.
- The bending moment criterion for the neck is determined by the bending moment (Nm) around the horizontal axis where the neck and the head of the dummy are connected.
- The maximum value of the neck flexion bending moment (Nm).

(3) Chest damage value

- The maximum value of dummy chest resultant acceleration at cumulative time 3ms.
- The maximum value of rib compression and displacement in a dummy’s chest (ThCC : Thorax Compression Criterion).

(4) Femur damage value

The maximum value of a dummy’s right and left femoral compressive load.

(5) Ilium load (female 5 percentile dummies only)

As it pertains to the measured value of ilium load, in cases where collapses of over 1,000N within duration of 1ms are seen, it shall be deemed that the waist belt slipped from the pelvis. However, in cases where multiple changes in ilium load become apparent, judgment shall be made based upon the load collapse following the final rise in load.

Furthermore, in cases where ilium load is greater than the leanings above during rebound and decreases, the waist belt shall be deemed to have not slipped from the pelvis if the ilium load directly before the value decreases is under 2,400N. The time of rebound beginning shall be time where the relative velocity with the vehicle is 0, with waist velocity calculated from the resultant acceleration of front-back direction and up-down direction waist acceleration.

(6) TCFC : Tibia Compressive Force Criterion (male 50th percentile dummies only)

Tibia Compressive Force Criterion is the maximum value of compressive load in units of kN transmitted in an axial direction to each tibia.

(7) TI : Tibia Index (male 50th percentile dummies only)

Tibia index is the maximum value calculated based upon measured bend moment and axial load on the tibia. Examples of recorded measured and calculated electric measurement results according to sections 6.2.2 and 6.2.3 are indicated in appendix 5.

6.2.4 High-speed Photography

The behavior of test automobiles and dummies during collision indicated in diagram 3 is to be photographed via high-speed VTR. Strobe lights indicating the moment of collision are to be inserted in the angle of view of each camera.

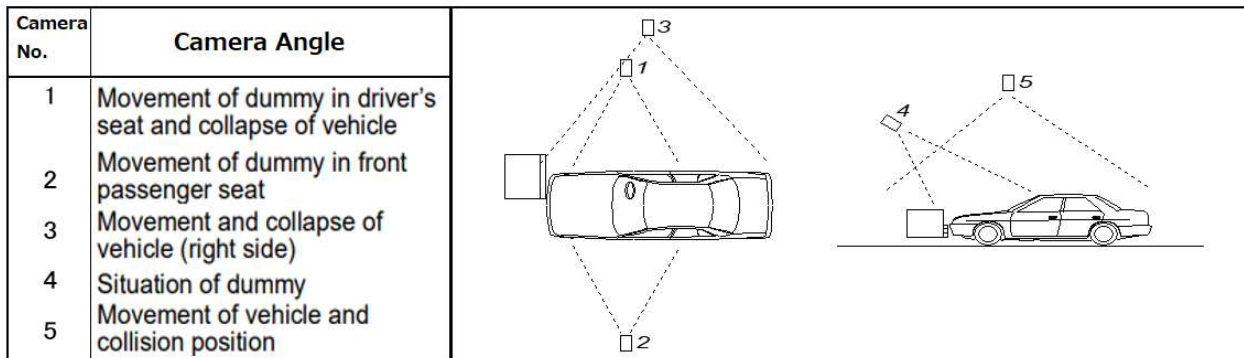

Diagram 3 Range of high-speed cameras

6.3 Post-test Records

6.3.1 Photographing of the state of the vehicle immediately following testing and secondary steering collisions of the driver seat dummy (test automobiles with a steering angle of over 32°)

- (1) Photographs of distinctive portions are to be taken immediately following a test and after confirming the ability of the side doors to open in section 6.3.2.
- (2) As it pertains to test automobiles with a steering angle of over 32°, photographs of the colored state of the pressure sensitive paper affixed to the driver seat dummy's chest and area near the chest (indication of contact with the steering rim) are to be taken.

6.3.2 Confirmation and Recording of the Ability of Side Doors to Open

The ability of side doors to open is to be confirmed for all test automobiles. At such times, whether or not a door opened with any of the methods indicated below is to be recorded. In cases where the door latch could not be undone as in (1), an attempt to undo the door latch shall be made with the inner handle, and if the latch can be undone, the ability of the door to open from (1) shall be confirmed once more, with record made that the latch was undone with the inner handle. In the event that the latch will not come undone even with the inner handle, proceed to the next step and continue confirming the ability of the door to open.

- (1) Door was able to be opened with one hand.
- (2) Door was able to be opened with both hands.
- (3) Door was able to be opened with tools.

6.3.3 Recording of seatbelt lead amount measurement results

Seatbelt lead amount is to be measured according to section 4.1.9.3, with the value recorded as seatbelt lead amount.

6.3.4 Confirmation and Recording of the Extractability of Dummies

After seatbelt lead amount has been measured according to section 6.3.3, the extractability of each dummy within the test automobile is to be confirmed. At this time, whether the dummy can be extracted from the test automobile with any of the methods indicated below is to be confirmed and recorded.

- (1) No tools used, and no manipulation of seat and steering system adjustment mechanisms.
- (2) No tools used, but manipulation of seat and steering system adjustment mechanisms took place.
- (3) Tools used.

In the event that steering system adjustment mechanisms were manipulated, the state before manipulation is to be marked, with the steering system returned to its original position before post-test vehicle dimension measurements are taken according to section 6.3.5.

6.3.5 Measurement and Recording of Post-test Vehicle Dimensions

Post-test vehicle dimensions are to be measured and recorded in the following manner.

- (1) Post-test vehicle dimensions are to be measured and recorded with the three-dimensional measuring device from the same position that pre-test vehicle dimension measurements were made according to section 6.1.4. Furthermore, differences in pre- and post-test measured values are to be calculated and recorded.
- (2) In instances where the steering system possesses a shear capsule structure and the steering column became separated from its mounting due to movement of the structure during collision, measurements are to be made and recorded after the column has been returned to its mounting as close to properly as possible.
- (3) Brake pedals are to be measured and recorded without any load applied. However, in the event a brake pedal is designed so as to come completely free of its mount during collision and comes free of its mount during collision, it is to be recorded that "the pedal came loose during testing and there is no longer any significant resistance to its movement remaining". In such cases, measurements of the brake pedal in an unburdened state are to be conducted and recorded just to be sure. Furthermore, in instances where a brake pedal is designed to detach or fall away from its mount during collision and detaches or falls away from its mount during collision, no measurements will be conducted, and it will be noted that "the pedal detached or fell away from its mount during testing".

6.3.6 Recording of Fuel Leakage Measurement Results

After collision, each part will be checked for the existence of fuel that has been discharged outside the vehicle or is dripping from it, with the results recorded.

6.3.7 Calibration and Recording of Accelerometers

After collision, accelerometers used during testing are to be calibrated, and the results are to be recorded.

6.4 Handling of Measurement Values

Measurement values are to be handled in the following manner.

- (1) Measurements of speed (km/h) are to be to 1 decimal place, with the next place rounded up.
- (2) Measurements of distance (mm) are to be to the integer position, with the next place rounded up.
- (3) Measurements of acceleration (m/s) are to be to 2 decimal places, with the next place rounded up.
- (4) Measurements of load (kN) are to be to 2 decimal places, with the next place rounded up.
- (5) Measurements of moment (Nm) are to be to 2 decimal places, with the next place rounded up.
- (6) Measurements of chest displacement are to be to 2 decimal places, with the next place rounded

up.

(7) Calculation of HIC is to be to 1 decimal place, with the next place rounded up.

(8) Calculation of tibia index is to be to 2 decimal places, with the next place rounded up.

APPENDIX 1: TEST VEHICLE SPECIFICATION DATA SHEET

[For Entry by the vehicle manufacturer and importer]

1. Seat and Seat Belt Adjustments

1st Row

			Driver's seat	Front passenger seat
① Adjustment of seat in fore-and-aft direction	Adjustment amount per stage		mm	mm
	Entire adjustment amount		mm	mm
	Middle position	From front edge	mm (stage)	mm (stage)
		From rear edge	mm (stage)	mm (stage)
② Adjustment of seat-slide-rail in attaching angle			°	°
③ Adjustment of seat lower and seat back at once	Design standard position			
	Adjustment method			
④ Adjustment of seat back angle	Design standard angle		° (stage)	° (stage)
⑤ Adjustment of seat in up and down direction	Tilt	From lowest position	mm	mm
	Lifter		mm	mm
	Others		mm	mm
⑥ Adjustment of lumbar support	From release position			
⑦ Adjustment of anchorage for seat belt shoulder webbing	Adjustment range		mm (stage)	mm (stage)
	Design standard position		From top position mm (stage)	From top position mm (stage)
⑧ Adjustment of head-rest height	Adjustment range		From top position mm (stage)	From top position mm (stage)
⑨ Other adjustment mechanism ()	Design standard position			

2nd Row and 3rd Row

		2 nd row	3 rd row	
① Adjustment of seat in fore-and-aft direction	Adjustment amount per stage	mm	mm	
	Entire adjustment amount	mm	mm	
	Design standard position	From front edge	mm (stage)	mm (stage)
		From rear edge	mm (stage)	mm (stage)
④ Adjustment of seat back angle	Design standard angle	° (stage)	° (stage)	
⑦ Adjustment of anchorage for seat belt shoulder webbing	Adjustment range	From top position mm (stage)	From top position mm (stage)	
	Design standard position	mm (stage)	mm (stage)	
⑧ Adjustment of head-rest height	Adjustment range	mm (stage)	mm (stage)	
	Design standard position	From top position mm (stage)	From top position mm (stage)	
⑨ Other adjustment mechanism	Design standard position			

(Note) The number of stages for adjustment position shall start from the first locking position ("stage 0").

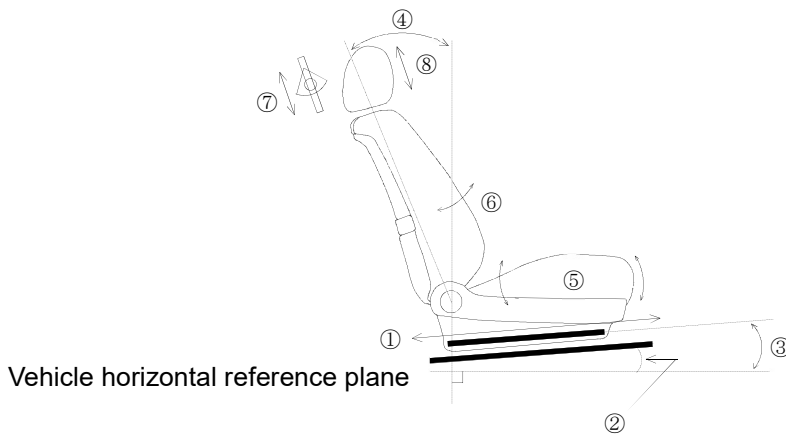

(Note) position of ⑨ other adjustable mechanism shall be shown on the above drawing.

2. Adjustment of Steering System

- (1) Vertical direction: (present, absent)
 Adjustment range: _____° ~ _____° (_____ stage)
 Vertical adjustment position:
 From uppermost position _____° (_____ stage)
- (2) Fore-and-aft direction
 Adjustment range: _____ mm (_____ stage)
 Fore-and-aft adjustment position:

From most forward position _____ mm (_____ stage)

(Note) The number of stages for adjustment position in the vertical directions and the fore-and-aft directions shall start from the uppermost position and front position ("stage 0"), respectively.

(3) Distance between steering pad center and forward end of steering shaft: _____ mm

3. Fuel Tank Capacity: _____ liters

In the event that the weight loading positions are designated when measuring stored weight, they are to be indicated on the diagram below.

Diagrams or pictures maybe used.

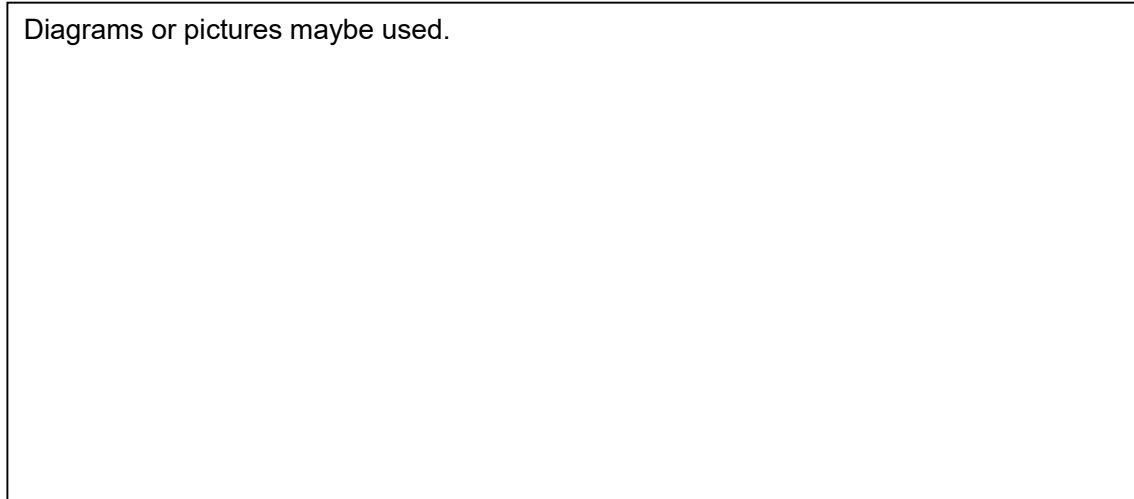

4. Total vehicle width: _____ mm

5. Reference Points of Measurement of Vehicle Inclination

(Enter inclination of unloaded vehicle with two dummies using this test placed on specified seats.)

(1) Fore-and-aft directions

Reference points (Number of points): _____

(Points shall be indicated in the figure below.)

Angle to horizontal surface: _____°

(2) Lateral directions

Reference points (Number of points): _____

(Points shall be indicated in the figure below.)

Angle to horizontal surface: _____°

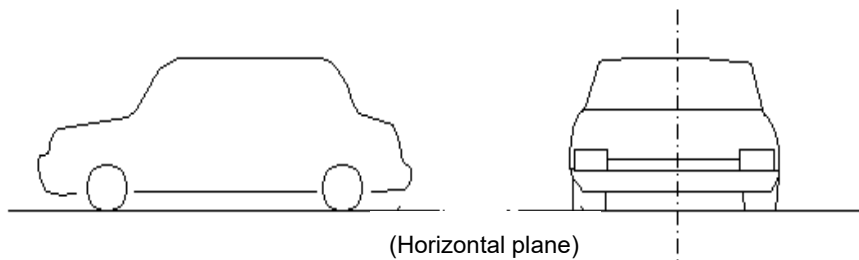

6. Relationship of line A and designed hip point

The relationship between the straight line A and the hip point shall be illustrated below if the dummy had to be set at a point other than the mid-point in the fore-and-aft direction in order to position the dummy properly when the hip point is located closer to the accelerator pedal than the straight line A prescribed in the Paragraph 4.5.1.(1). The amount of adjustment from the middle position shall also be indicated.

Amount of adjustment from the middle position: _____ mm (_____ stage)

7. Location and Method for Installation of Vehicle Accelerometer

Entry shall be made using Appendix 3.

8. Removable parts

9. Automatic door lock systems

Vehicle speed activated door lock system: _____ Y (_____ sensor) / N _____

Impact sensing type door lock release system: Y / N

10. Installation of Towing Hook

Towing hook shall be installed at the center of the test vehicle.

Diagrams or photographs may be used.

11. Points of reference for vehicle measurement criteria

After the collision test has been carried out, locations from point 3 to point 5 that are unlikely to have been affected by vehicle body deformation are to be indicated.

Diagrams or photographs may be used.

12. Bolt fastening torques

- Driver seat airbag module : N
- Driver seat anchor bolts : N
- Passenger seat anchor bolts : N
- Others : N
- : N
- : N

13. Measurement, Record for Dummy Design Standard Seating Position

① Recording sheet for simple measurement

[For entry by vehicle manufacturer]

Model name and type _____	Test Date Y M D
Frame number _____	Test Site _____
Type of dummy _____	Measured _____
Dummy number _____	by: _____
	Remarks _____

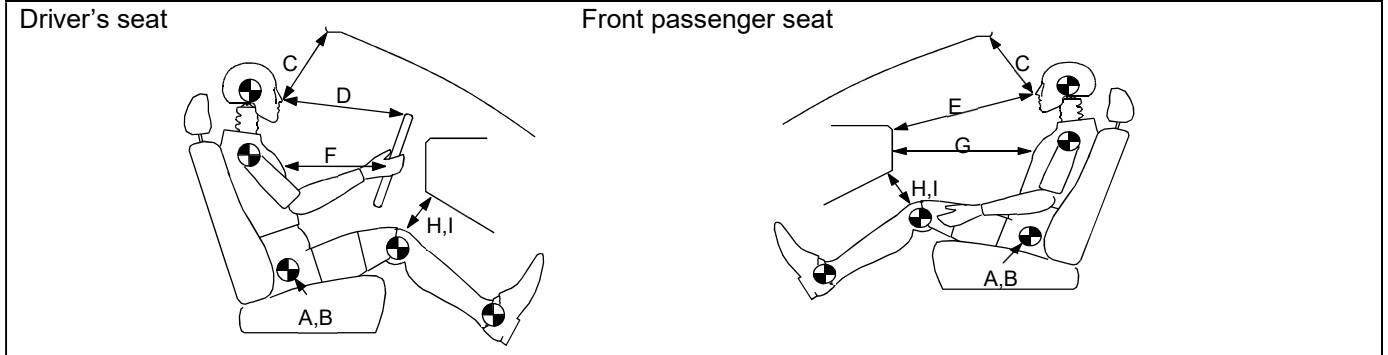

Measurement items	Driver's seat	Front passenger seat
A Reference point () ~ Hip point, in fore-and-aft direction		
B Reference point () ~ Hip point, in vertical direction		
C Top of nose ~ Windshield header		
D Top of nose ~ Steering wheel rim upper center		
E Top of nose ~ Dash board		
F Chest ~ Steering horn pad surface (horizontal)		
G Chest ~ Dash board (horizontal)		
H Right knee ~ Lower section of dash board		
I Left knee ~ Lower section of dash board		
J Head angle (only hybrid III)		
K Pelvis angle (only hybrid III)		
L		

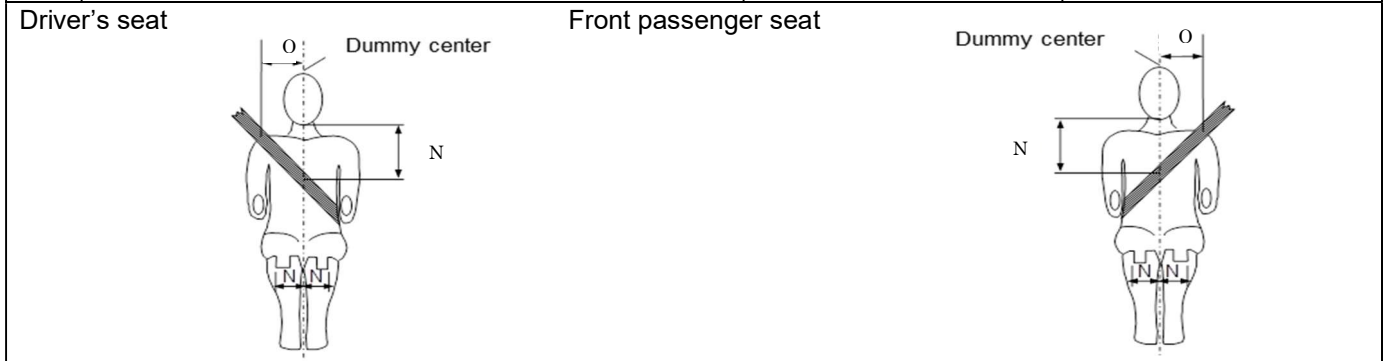

Measurement items	Driver's seat		Front passenger seat	
M Distance between knees (Dummy center ~ Right, left)	Right:	Left:	Right:	Left:
Reason why knee spacing cannot be mounted at defined intervals				
N Dummy lower section of jaw ~ Belt center (Vertical direction on dummy centerline)				
O Dummy center ~ Belt center (Lateral direction at height of root of neck)				
P				

(Note) Positions that are to references for the vehicle are to be entered as reference points () in A and B with the dimensions of their vertical and longitudinal components measured. Reference points do not have to be identical.

13-1. Measurement, Record for Dummy Seating Position

① Recording sheet for simple measurement

[for entry by testing institute]

Model named model year _____	Test Date	Y	M	D
Frame number _____	Test Site	_____		
Type of dummy _____	Measured by:	_____		
Dummy number _____	Remarks	_____		

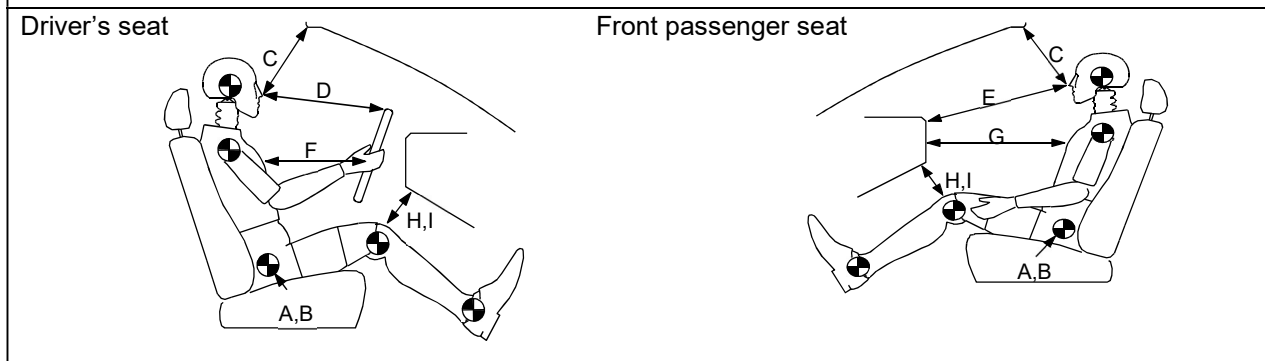

Measurement items	Driver's seat	Front passenger seat
A Reference point () ~ Hip point, in fore-and-aft direction		
B Reference point () ~ Hip point, in vertical direction		
C Top of nose ~ Windshield header		
D Top of nose ~ Steering wheel rim upper center		
E Top of nose ~ Dash board		
F Chest ~ Steering horn pad surface (horizontal)		
G Chest ~ Dash board (horizontal)		
H Right knee ~ Lower section of dash board		
I Left knee ~ Lower section of dash board		
J Head angle (only hybrid III)		
K Pelvis angle (only hybrid III)		
L		

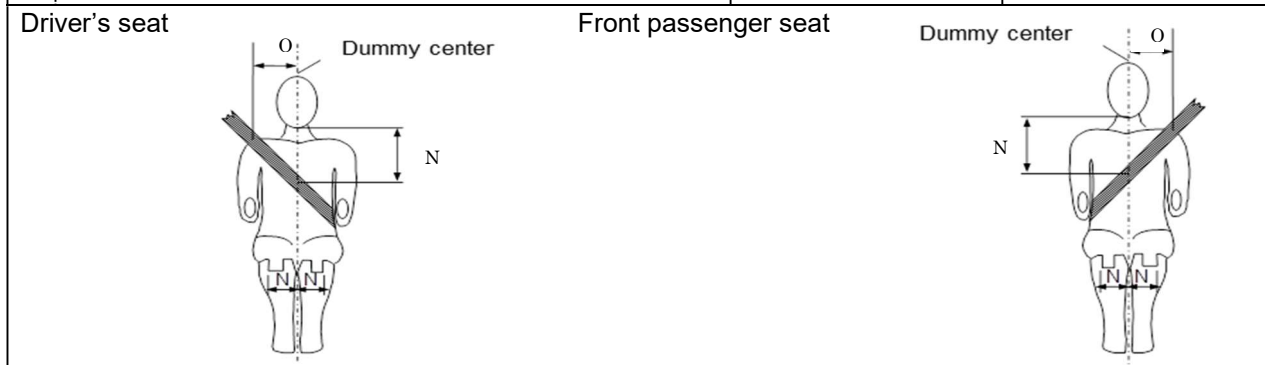

Measurement items	Driver's seat		Front passenger seat	
M Distance between knees (Dummy center ~ Right, left)	Left:	Right:	Left:	Right:
N Dummy lower section of jaw ~ Belt center (Vertical direction on dummy centerline)				
O Dummy center ~ Belt center (Lateral direction at height of root of neck)				
P				

(Note) For items A and B, the parts, which constitute the reference of the vehicle body, shall be entered in parentheses () for the reference point. Then, dimensions of fore-and-aft and vertical components shall be measured. It is not necessary that the same reference points be employed.

② Record sheet for three-dimensional measuring device

Model name and type _____	Test Date	Y _____	M _____	D _____
Frame number _____	Test Site	_____		
Type of dummy _____	Measured by:	_____		
Dummy number _____	Remarks	_____		

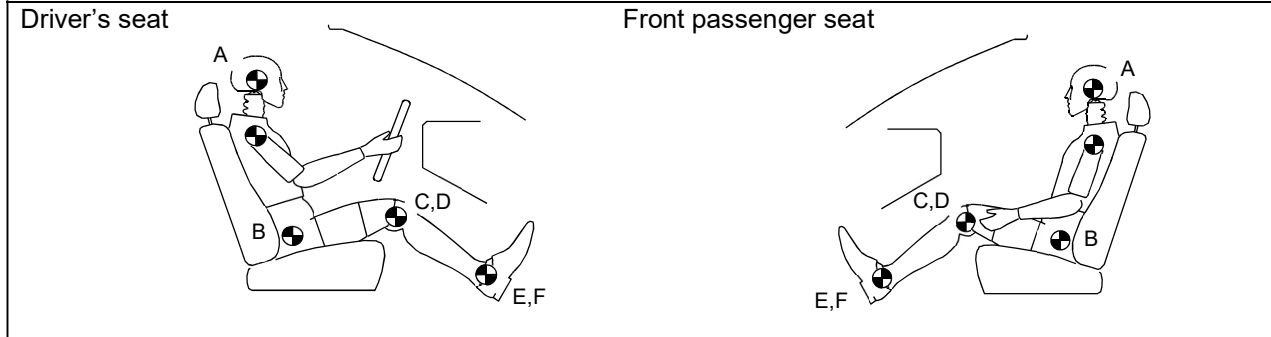

Measurement items (target value)	Driver's seat			Front passenger seat		
	X	Y	Z	X	Y	Z
A Position equivalent to head center						
B Hip point						
C Knee joint center right (outer side of vehicle)						
D Knee joint center left (outer side of vehicle)						
E Heel center right						
F Heel center left						
G Head angle						
H Pelvis angle						
I Neck bracket stages						

13-2. Detached parts and loaded weight.

<u>Detached parts</u>	
<u>Loaded weight mass</u>	

Loaded Weight locations

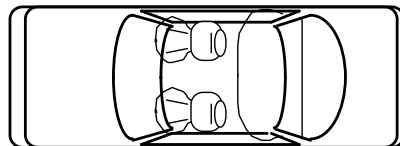

14. Automobile manufacturer test results

Automobile manufacturers are to attach their own test results in a form equivalent to Appendix 5 as needed.

APPENDIX 2: EXAMPLES OF HOW TO MEASURE AMOUNT THAT SEATBELT IS PULLED OUT OR DRAWN IN

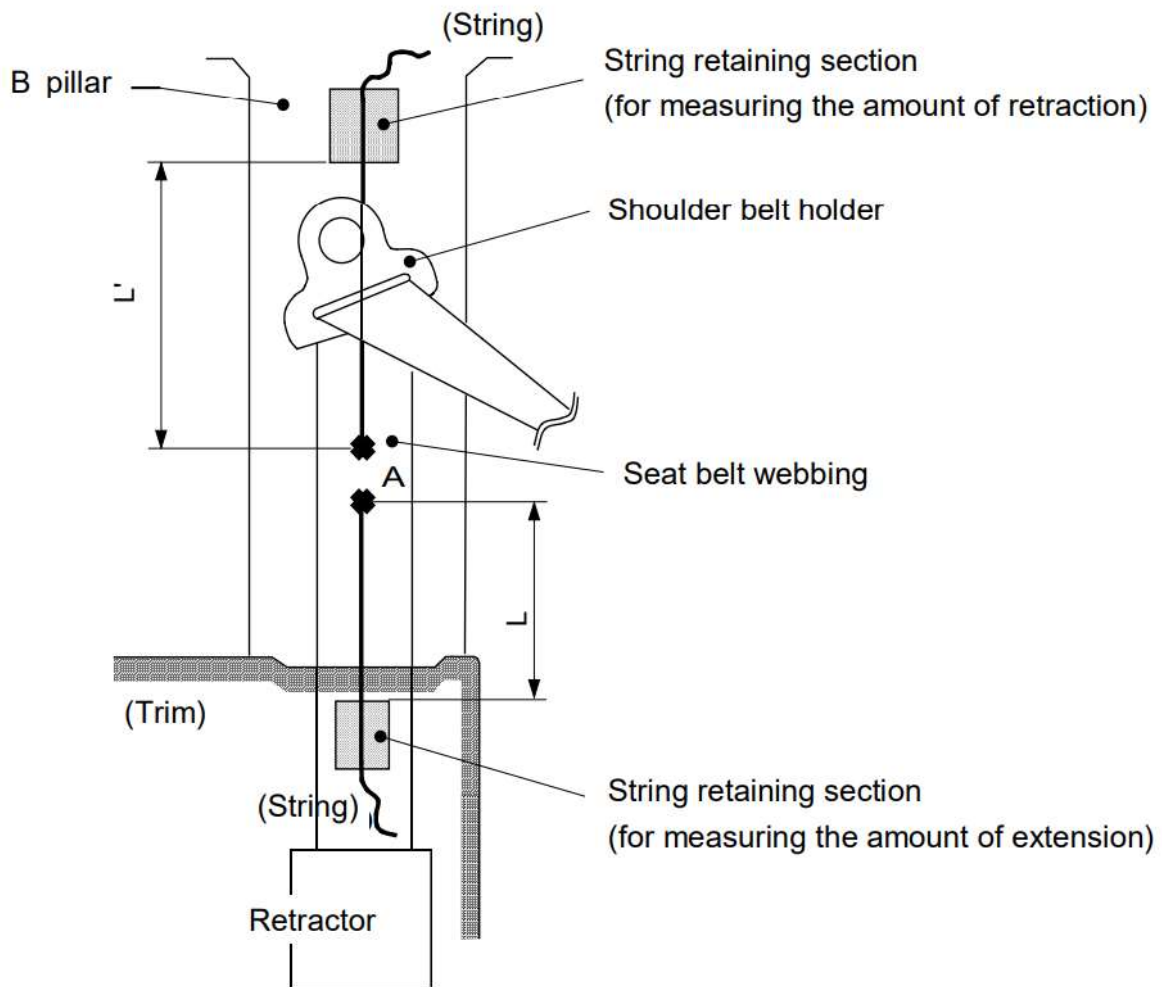

- ① Attach the end of the thread to the seatbelt strap portion (Diagram A: sew it on, or use tape to hold the thread in place).
- ② Attach the thread retainer to the trim concealing the winding apparatus as shown in the diagram (For example something with the end inserted into a piece of Styrofoam). The thread should be held in place so that it moves smoothly when the seatbelt is drawn out.
- ③ Measure the post-test dimensions as seen in diagram L, the difference being the amount drawn out.
 In cases where there is a pretensioner, the thread retainer is to be attached to the side of pillar B, then measure the post-test dimensions as seen in diagram L, the difference being the amount drawn out.

APPENDIX 3: POSITION WHERE ACCELEROMETERS ARE AFFIXED TO THE TEST AUTOMOBILE.

[For entry by the test laboratory]

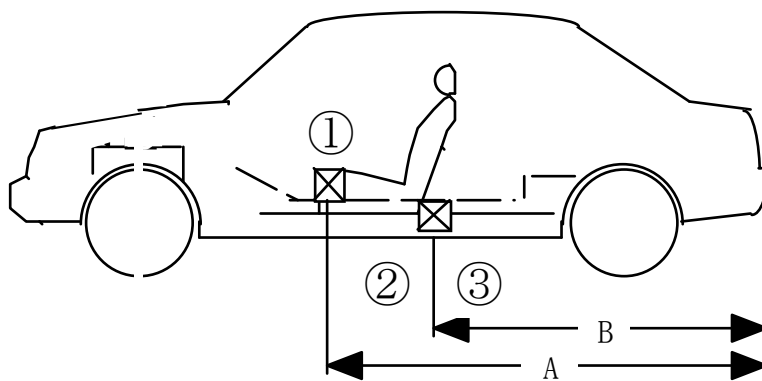
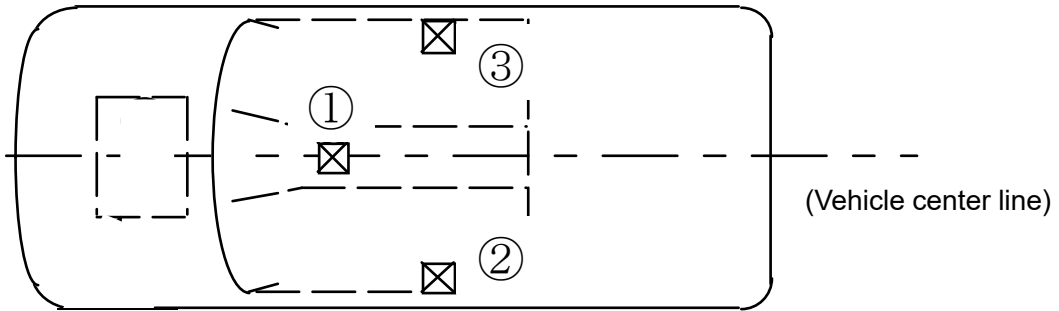

Measurement location	Distance from vehicle dimension measurement reference position (mm)
① Tunnel A	A:
② Left side sill	B:
③ Right side sill	B:

APPENDIX 4: TEST AUTOMOBILE DIMENSION DATASHEET

[For entry by the test laboratory]

Model name, model type, and classification		
Frame number		
Body style		
Engine type		
Drive type		
Transmission type		
Steering system	Steering wheel type	
	Air bag	Absent / Present
	Adjustment in the vertical direction	Absent / Present (Electric / Manual)
	Adjustment in the fore-and-aft direction	Absent / Present (Electric / Manual)
Seat	Adjustment in the fore-and-aft direction	Absent / Present (Electric / Manual)
	Adjustment of seat back	Absent / Present (Electric / Manual)
	Adjustment of lumbar support	Absent / Present (Electric / Manual)
	Adjustment of height	Absent / Present (Electric / Manual)
Seat belt	Pre-tensioner	Absent / Present (Shoulder / Inside of waist)
	Adjustment of shoulder webbing	Absent / Present (Electric / Manual)
Others (Circle around items present)		Air conditioner / Power steering / Vehicle speed sensing door lock / Sunroof / Traction control / ABS / Air bag for front passenger seat / Foot rest

APPENDIX 5: RECORDED EXAMPLES OF ELECTRICAL MEASUREMENT RESULTS

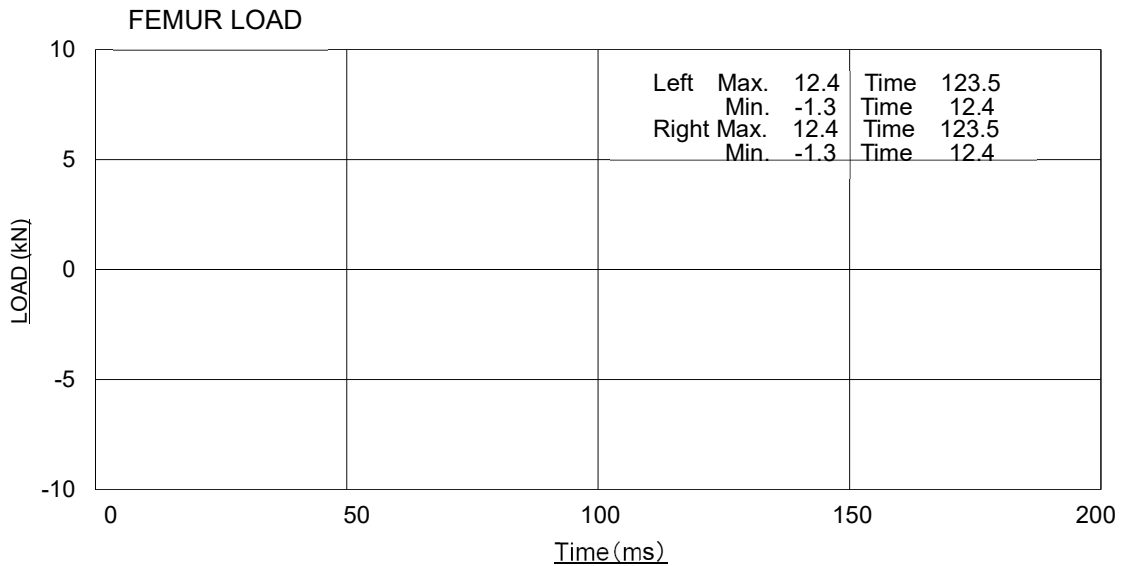
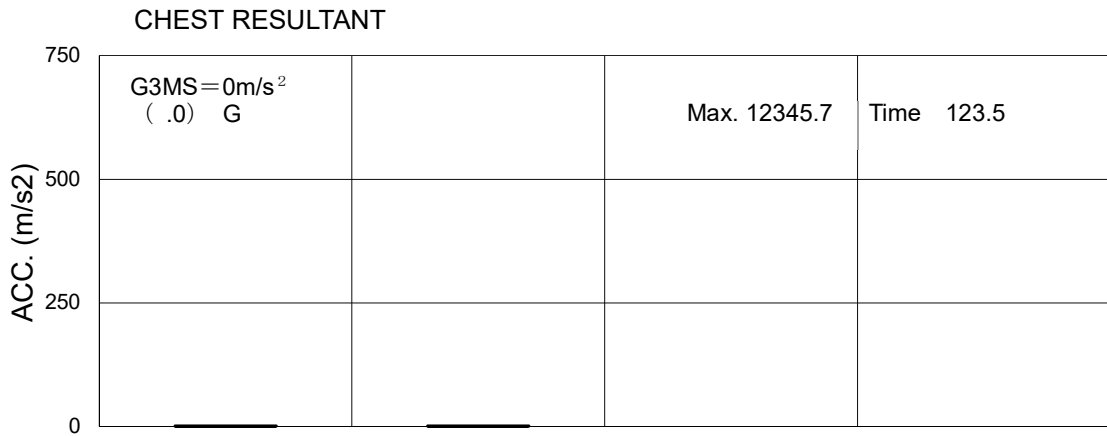
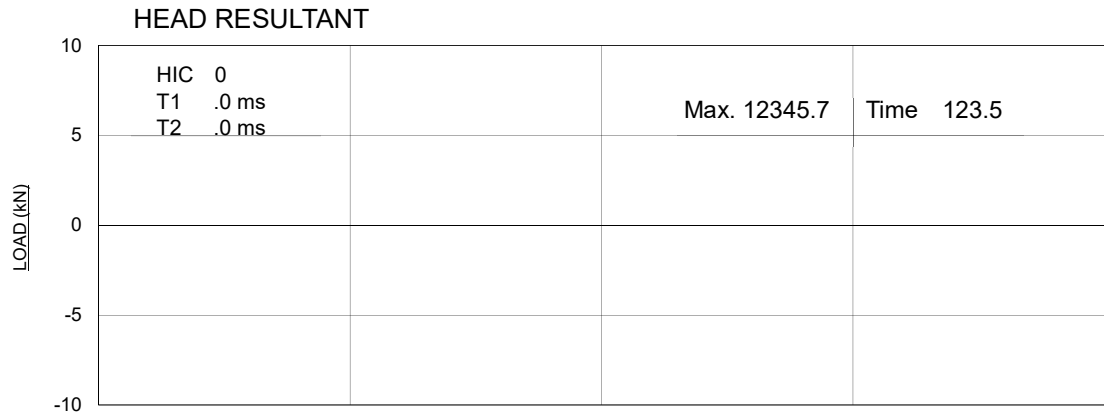

Driver (or Passenger) Dummy

No. NASVA****_****_***

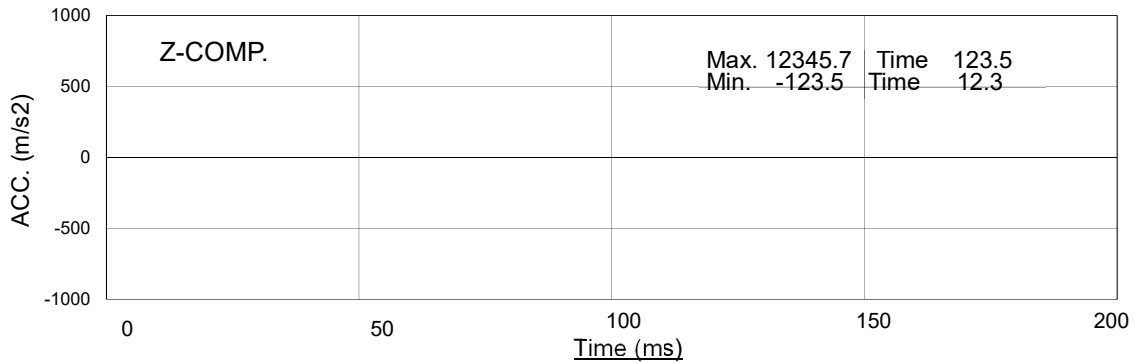
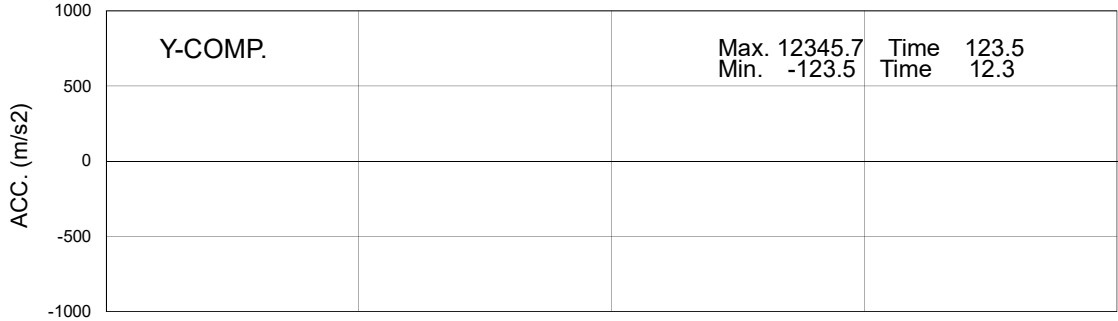
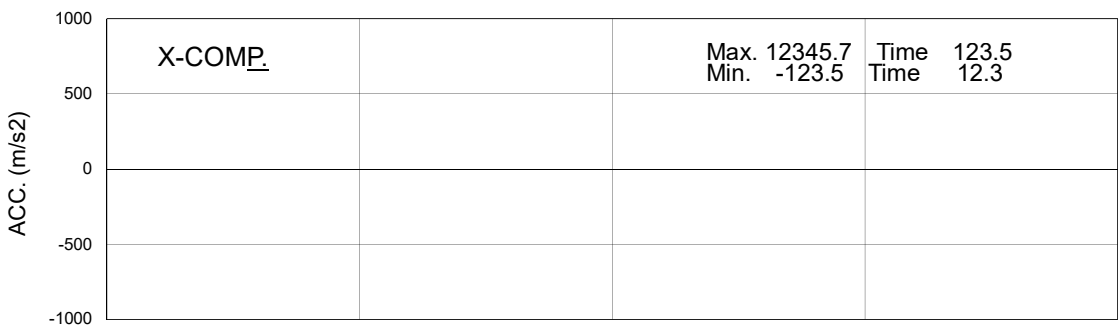

Driver (or Passenger) Dummy Head Acc.

No. NASVA ****_****_***

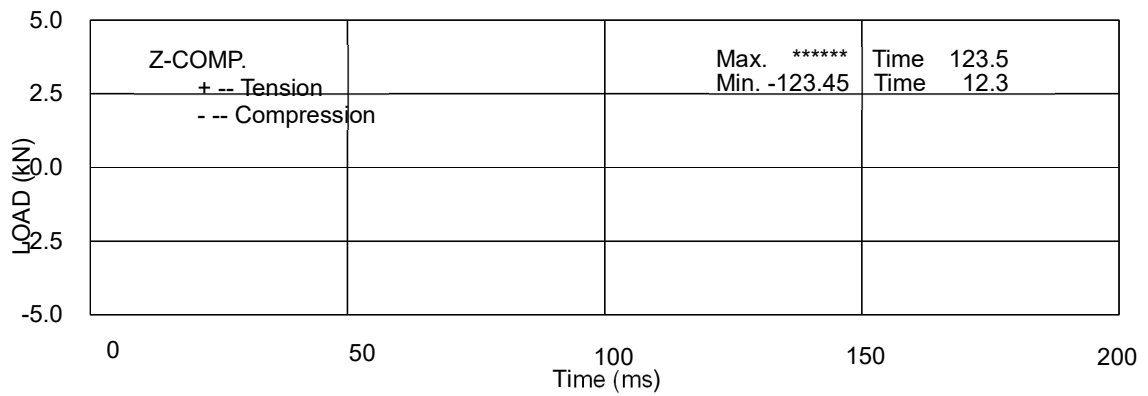
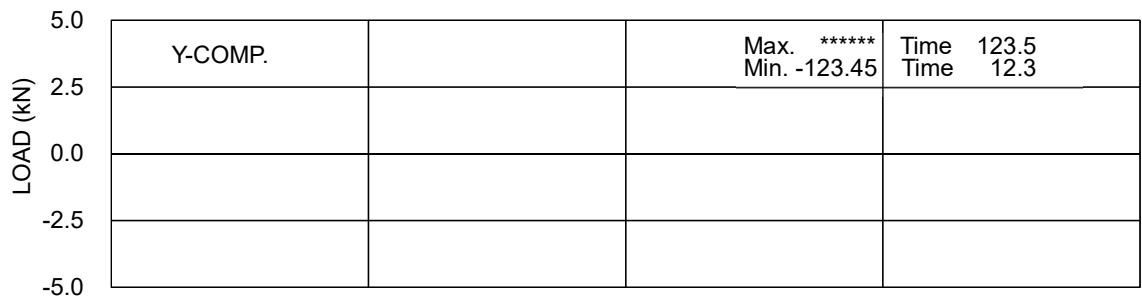
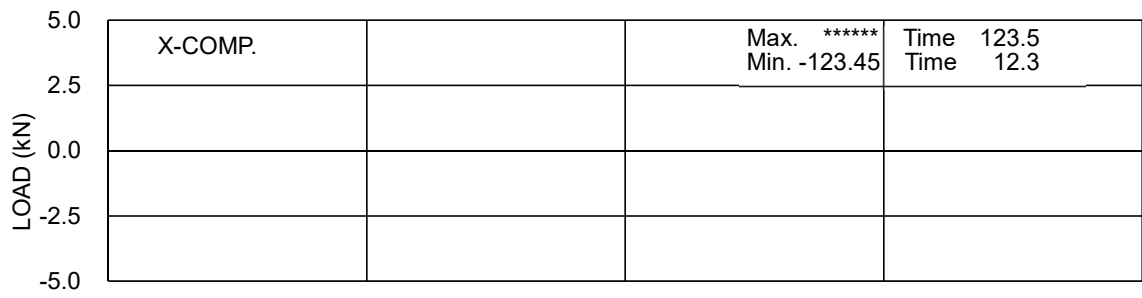

Driver (or Passenger) Dummy Neck Force

No. NASVA****_****_***

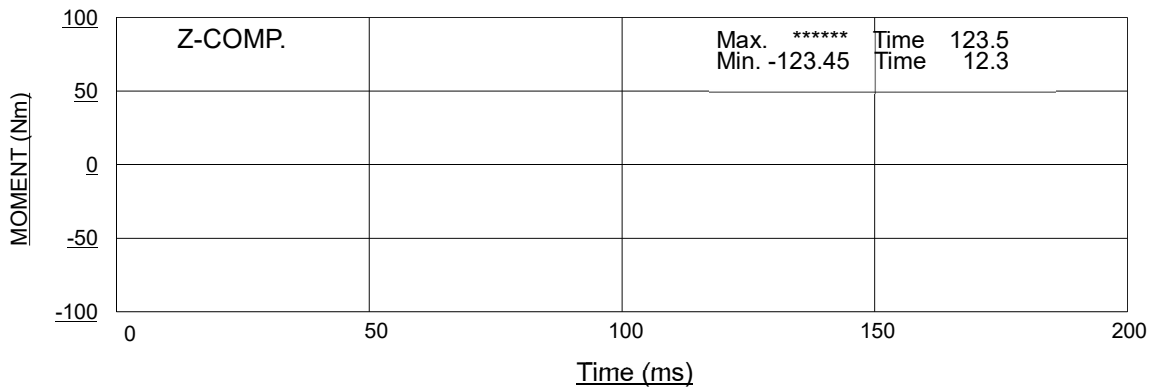
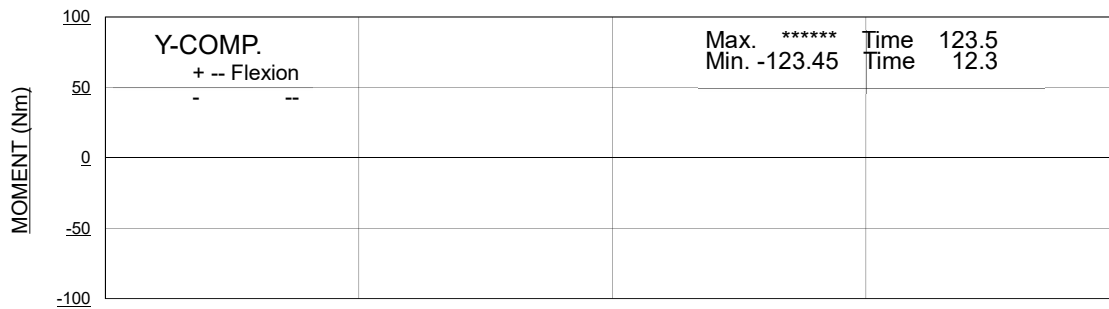
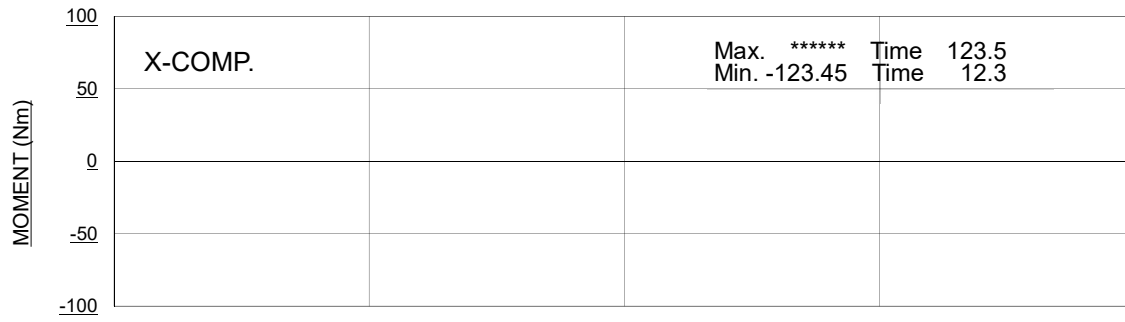

Driver (or Passenger) Dummy Neck Moment

No. NASVA ****_****_***

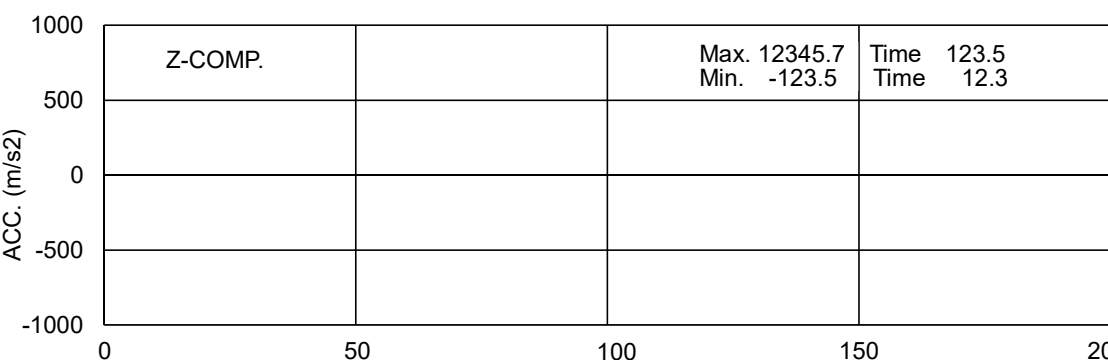
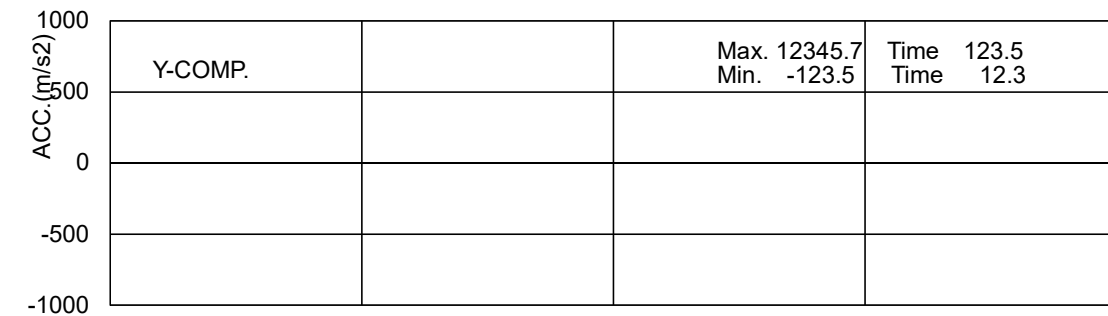
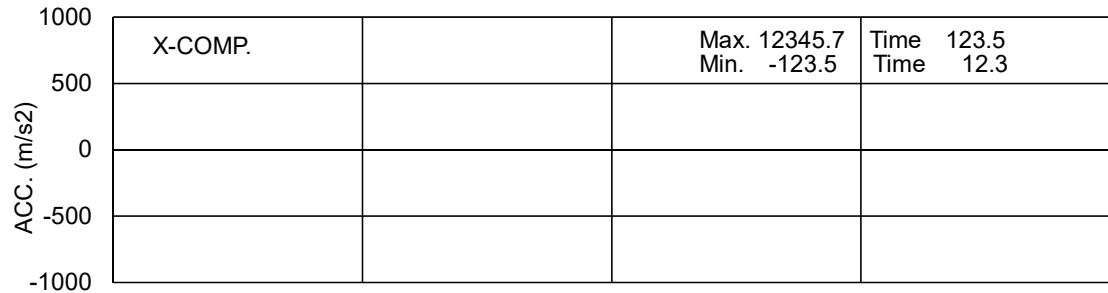
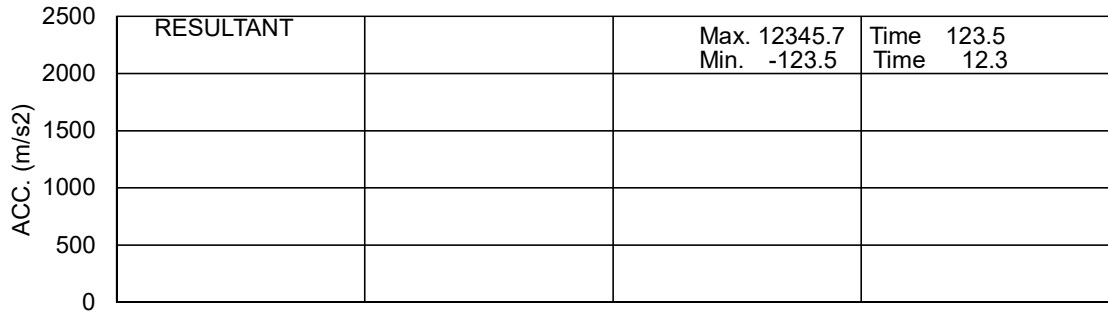

0 50 100 150 200
Time (ms)

Driver (or Passenger) Dummy Chest Acc.
No. NASVA****_****_***

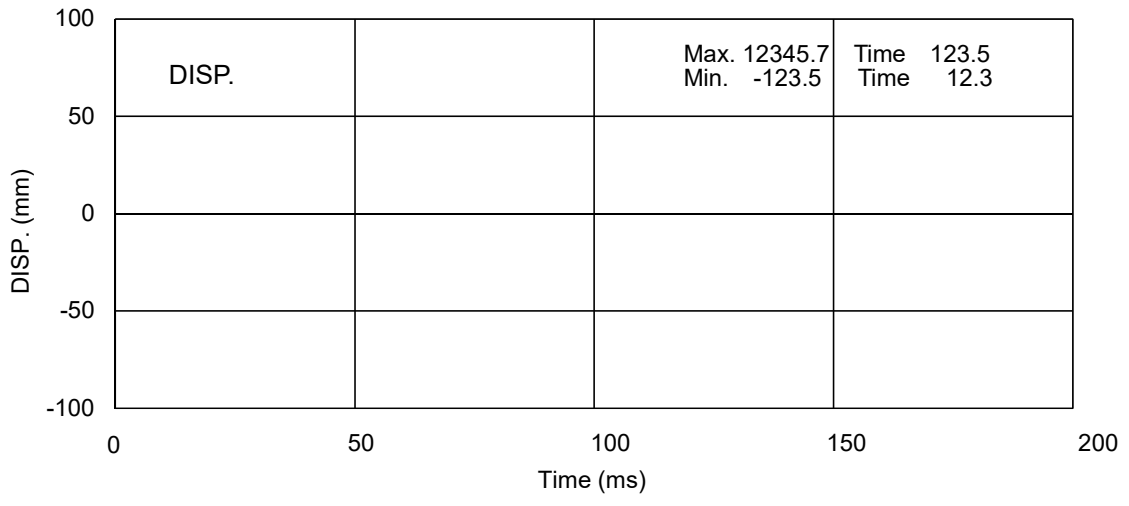

Driver (or Passenger) Dummy Chest Disp.

No. NASVA****_****_***

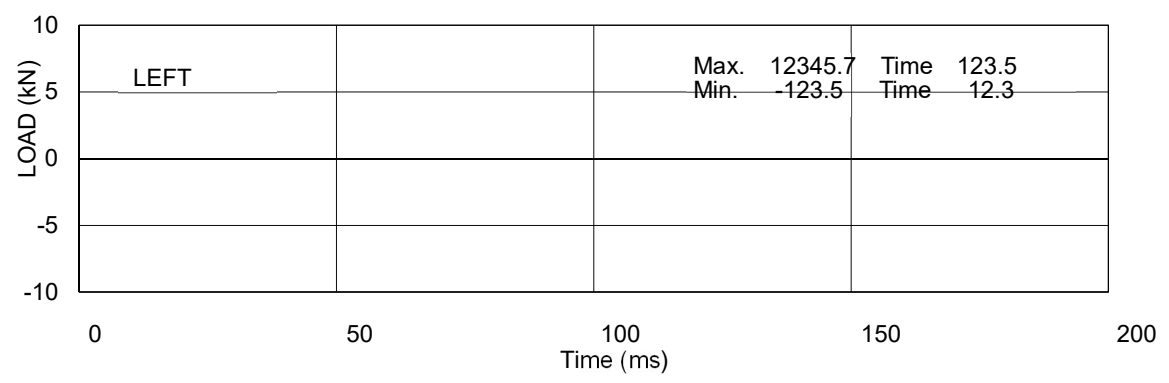
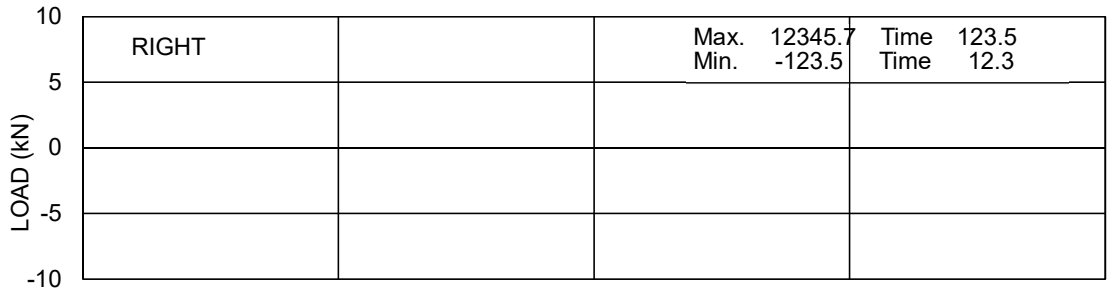

Driver (or Passenger) Dummy Femur Force
 No. NASVA****_****_***

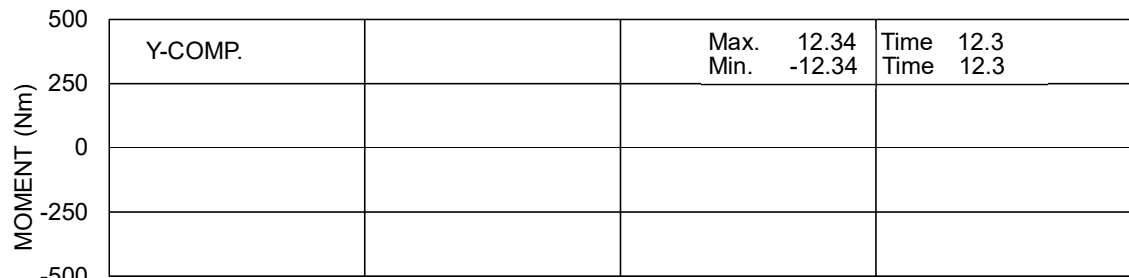
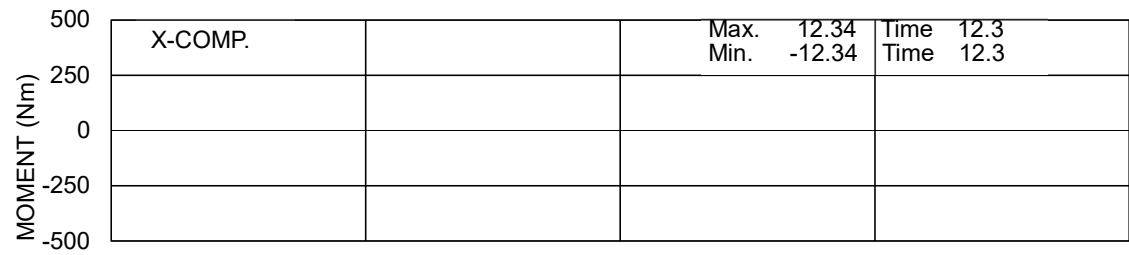
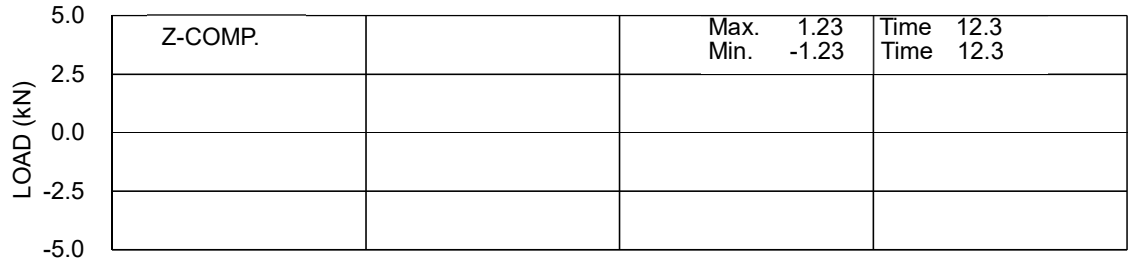
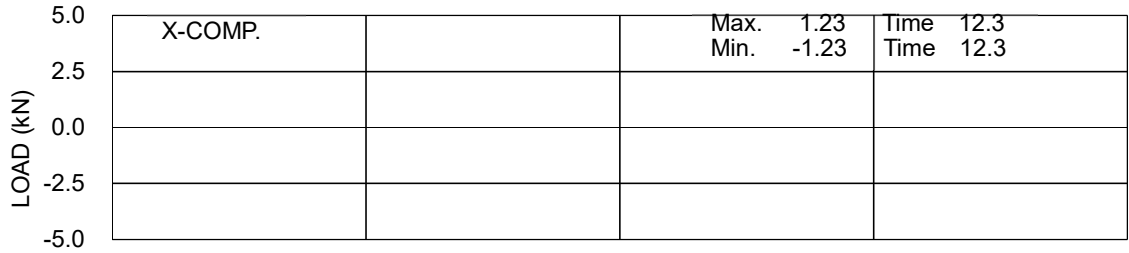

0 50 100 150 200
Time (ms)

Driver (or Passenger) Right Tibia Upper F & M

No. NASVA****_****_***

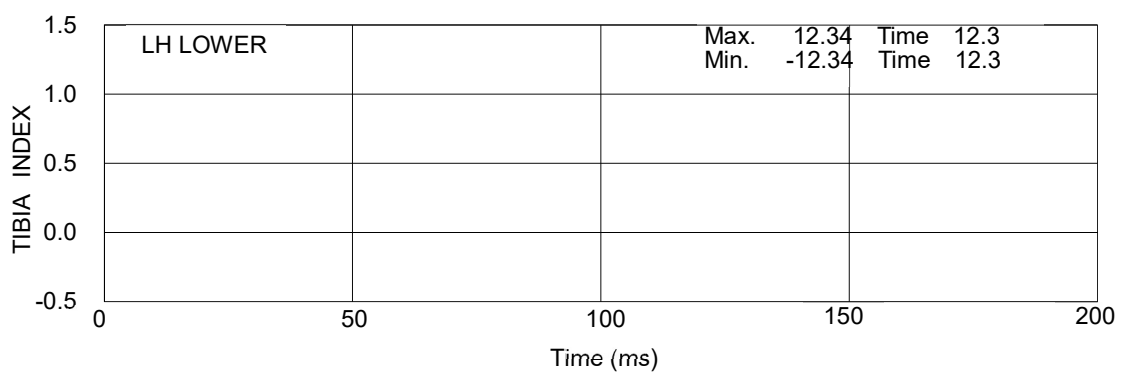
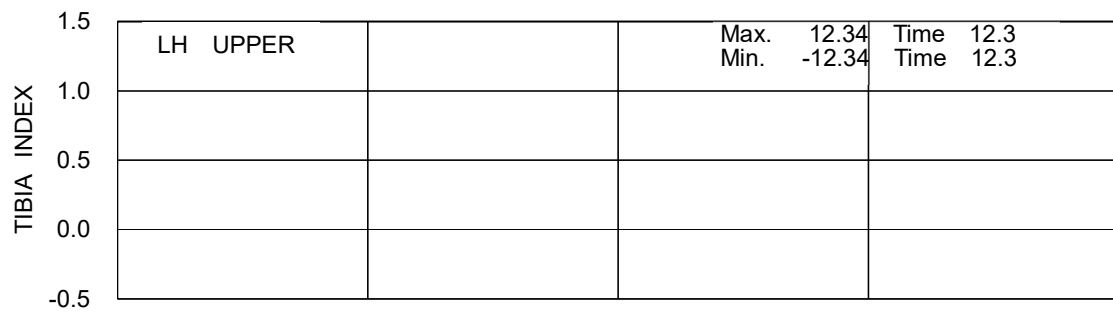
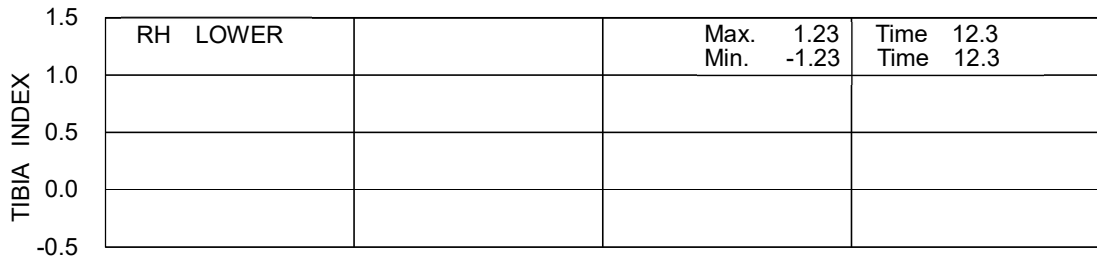
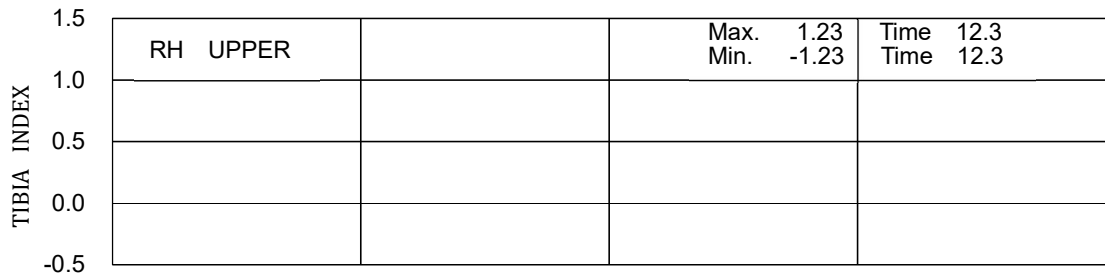

Driver (or Passenger) Dummy TI
 No. NASVA ****_****_***

POTENTIAL FOR SIGNIFICANT NECK INJURY
DUE TO AXIAL NECK TENSION LOADING

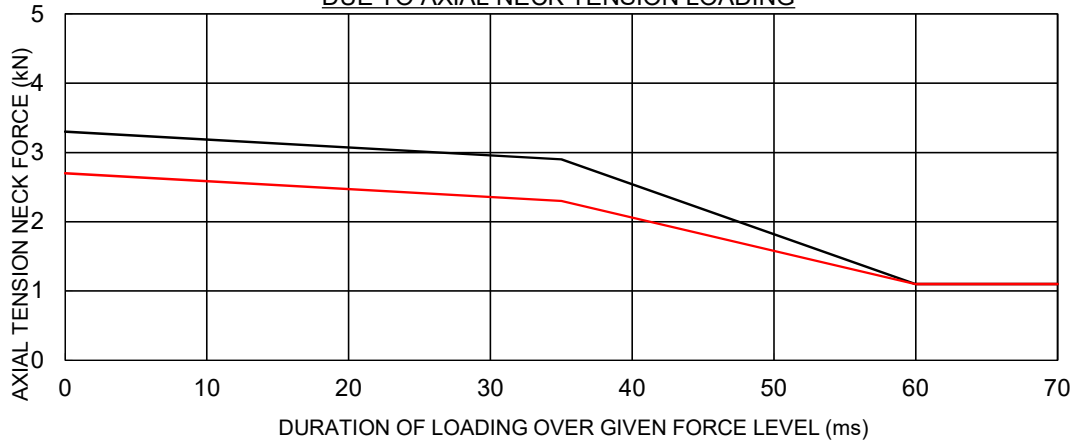

POTENTIAL FOR SIGNIFICANT NECK INJURY
DUE TO FORE/AFT SHEAR LOADING

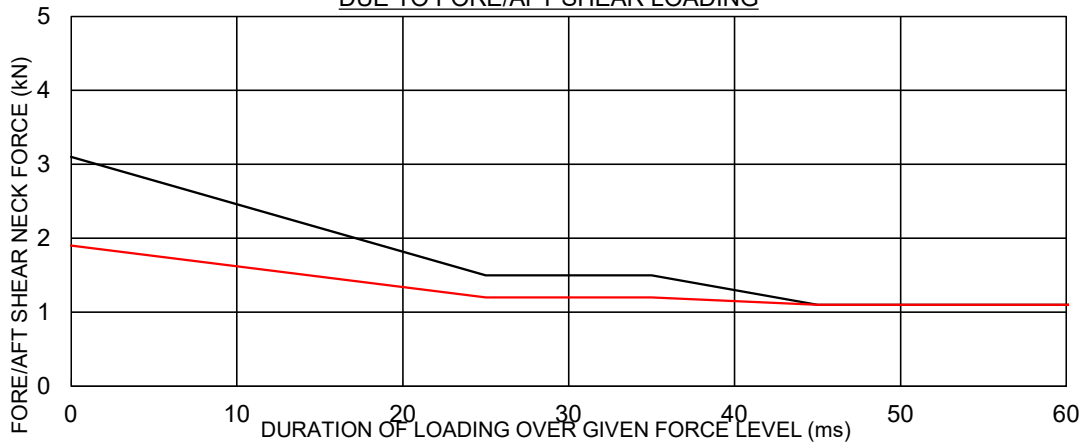

POTENTIAL FOR SIGNIFICANT NECK INJURY
DUE TO FORE/AFT SHARE LOADING

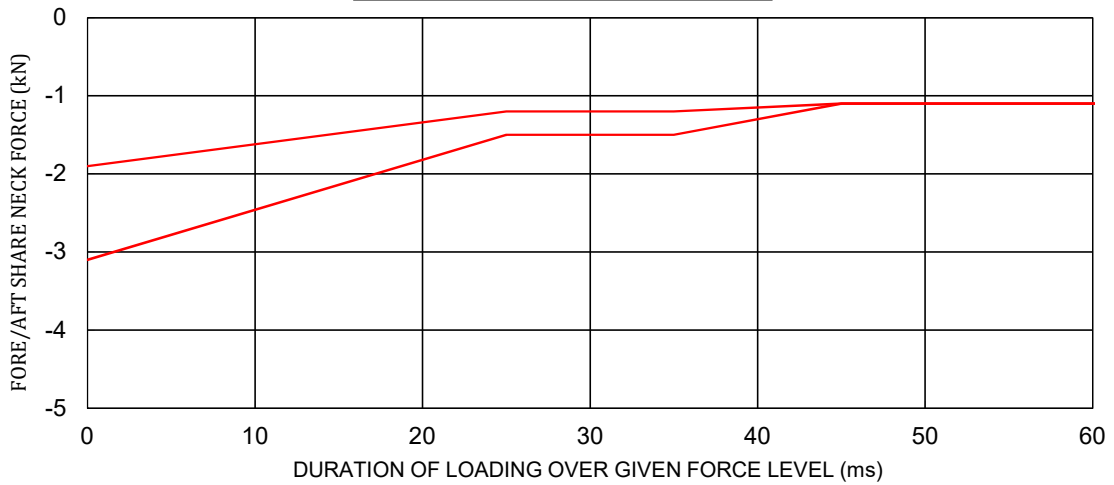

Driver Dummy

No. NASVA****_****_***

POTENTIAL FOR FRACTURE OF THE FEMUR

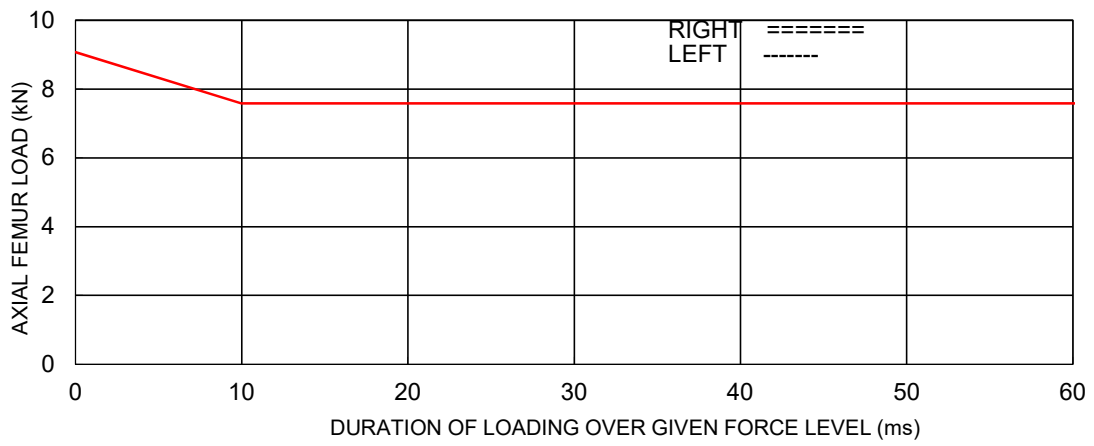

Driver Dummy

No. NASVA****_****_***

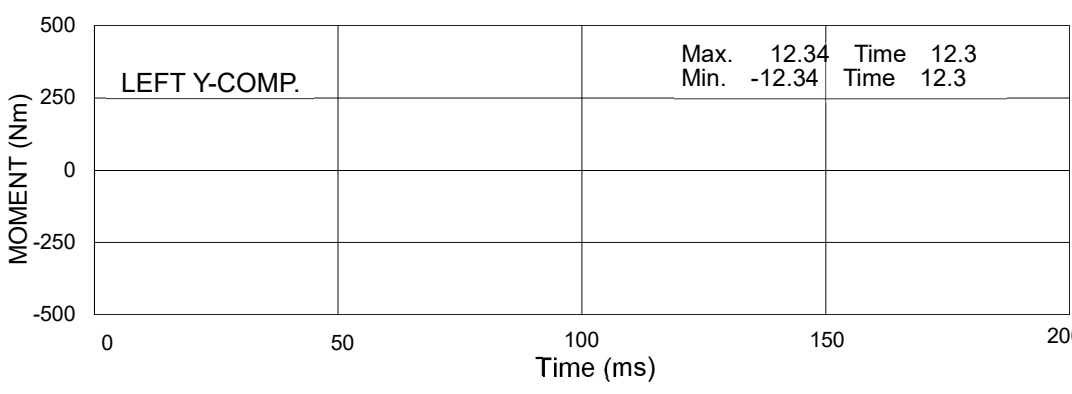
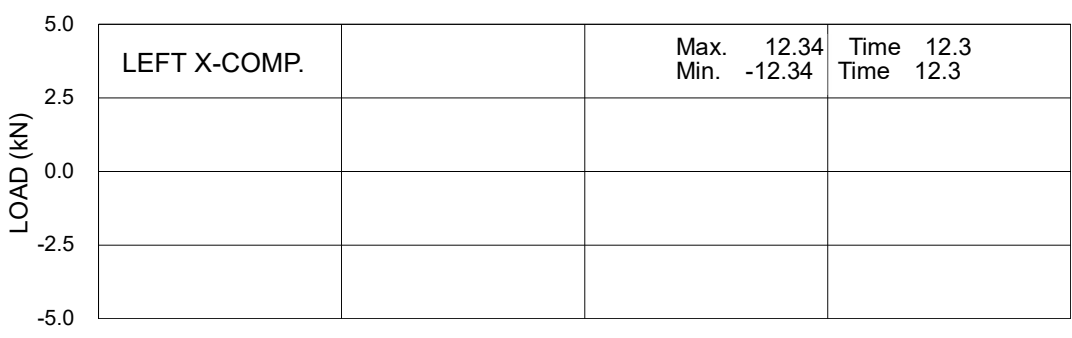
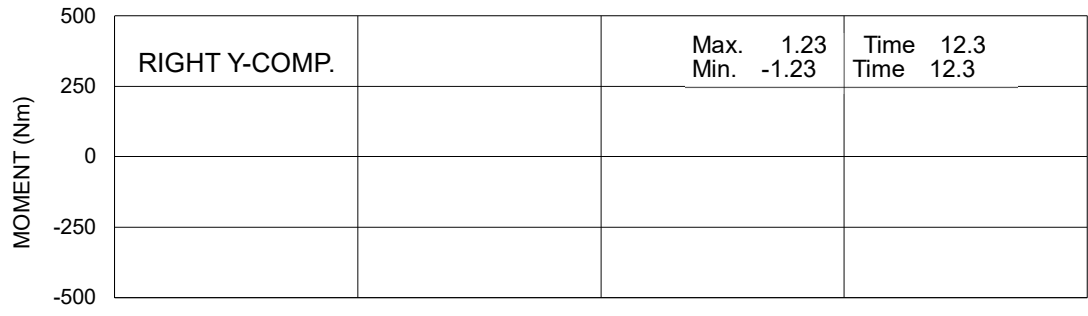
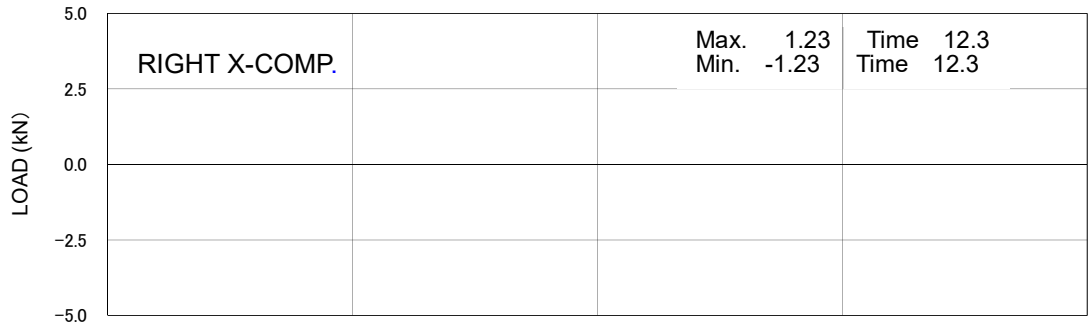

Passenger Dummy Iliac F & M
 No. NASVA ****-****-***

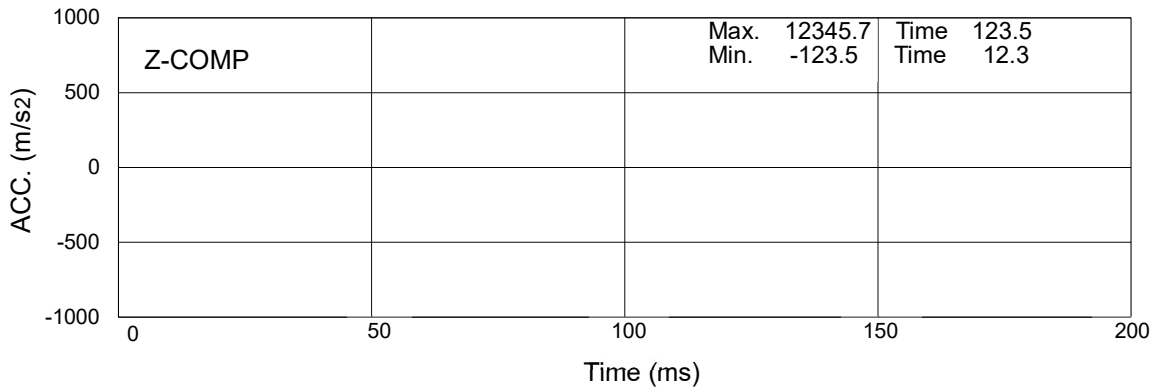

Passenger Dummy Pelvis Acc.

No. NASVA ****_****_***

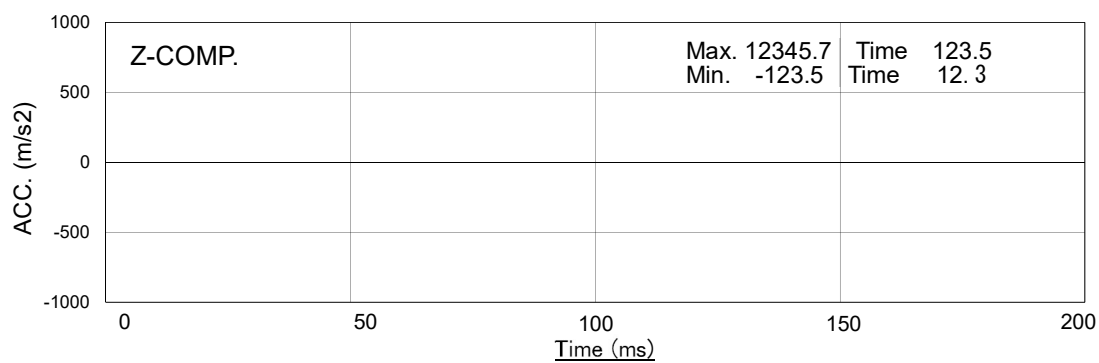
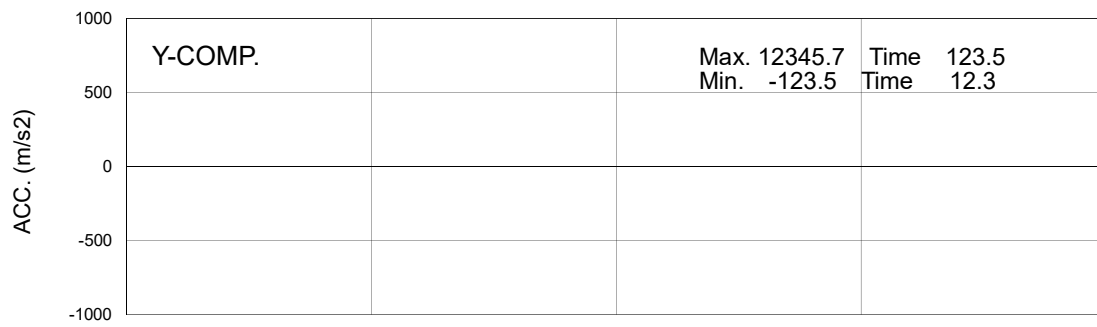
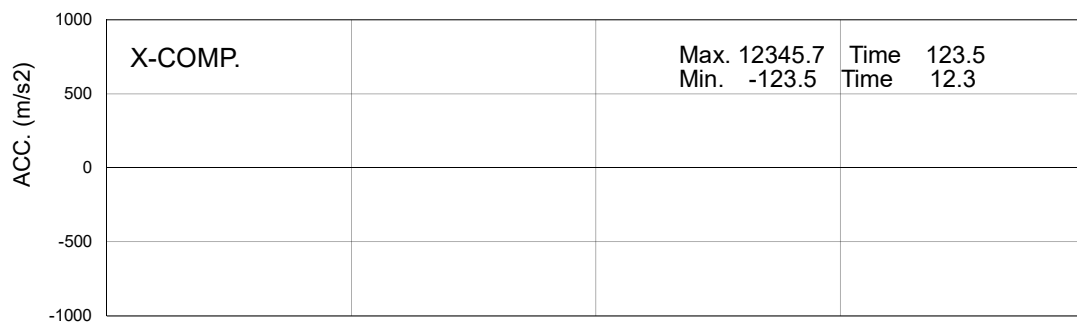
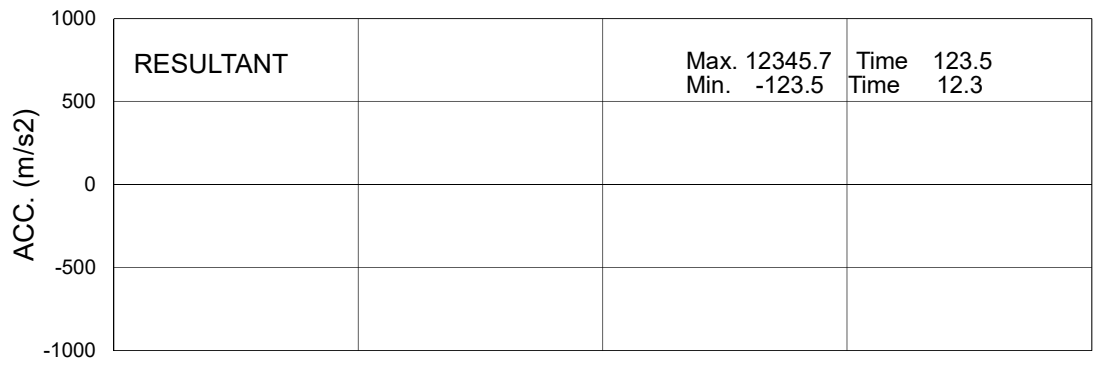

Vehicle Tunnel. Acc.
 No. NASVA****_****_***

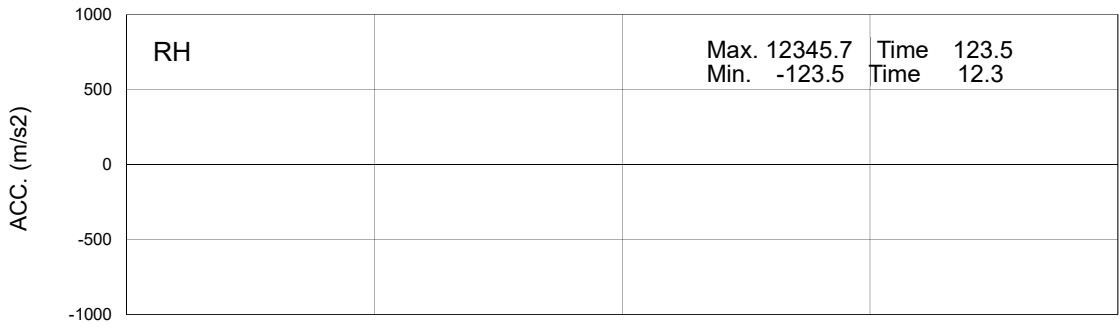

Vehicle Side Sill Acc.
 No. NASVA****_****_***

DUMMY LOADING METHOD

Dummies shall be loaded into the driver seat of test automobiles following the steps below.

1. Seat Position

- (1) Confirm that the adjustment holes on the dummy's chest (that the jacket and each other adjustment hole is not out of place, and in a state where the adjustment tools can be inserted and used) are in an appropriate state before loading the dummy.
- (2) Match the dummy's left, right, and center with the designed seat center.
- (3) Place the dummy's torso against the seat back.

2. Setting Leg Positions

- (1) Match both knees to the initial interval in diagram 1. These dimensions are not meant to stipulate the final position of the knees.

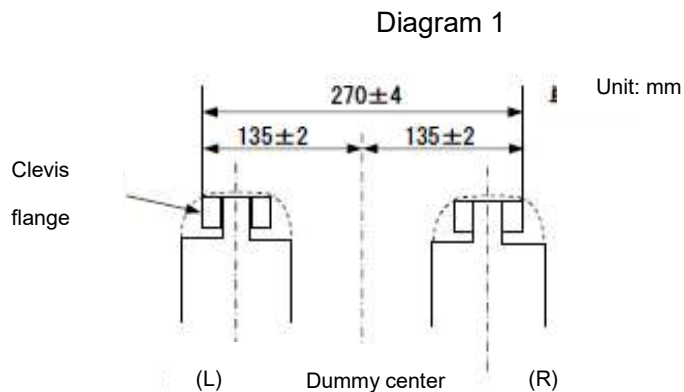

- (2) The right foot is to be placed upon the acceleration pedal in an undepressed state, with the heel set upon the floor at the bottom end of the acceleration pedal.

Diagram 2

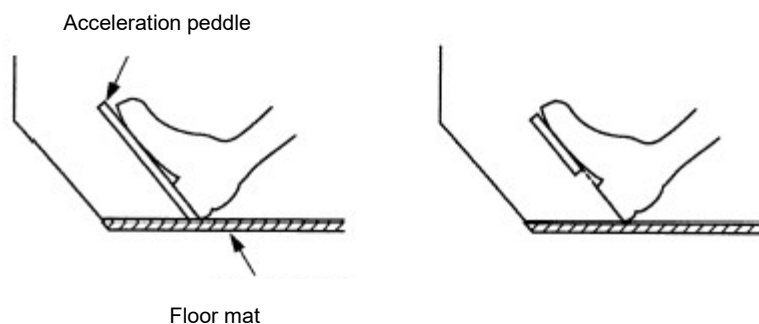

- (3) In cases where the plane formed by the femur and tibia of the right leg is not perpendicular, move and adjust the knee until it is as close to perpendicular as possible.
- (4) The left foot is to be set upon the floor with the heel as close as possible to the point where the toe board and floor pan intersect, with the foot set upon the toe board. In cases where the foot

does not reach the toe board, the foot is to be set at a right angle to the tibia and placed upon the floor as close as possible to the toe board. In cases where there is a footrest, the foot is to be placed upon the footrest.

Diagram 3 - If the foot reaches the toe board

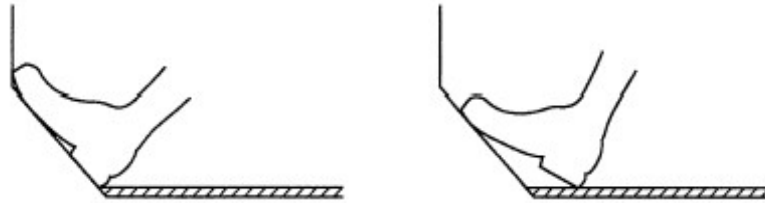

Diagram 4 - If the foot does not reach the toe board

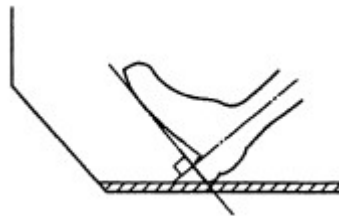
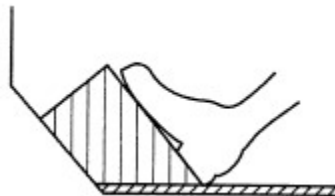

Diagram 5 - If there is a footrest



(5) In cases where the plane formed by the femur and tibia of the left leg is not perpendicular, move and adjust the knee until it is as close to perpendicular as possible. In cases where the foot interferes with the brake pedal or clutch pedal, the left foot is to be rotated as little as needed to center it with the tibia. If the foot is still in the way even after this, the femur may be rotated so that there is as little interference as possible.

3. Initial position of arms and hands

- (1) Upper arms are to be placed against the seat back, so that they also touch the upper body.
- (2) The lower arms and hands are to be placed along the outside of the femurs.

4. Setting the Position of the Upper Body

- (1) The dummy's hip point on the external side of the vehicle is to match a position that is left as-is in

terms of the front-back direction, from the designed hip point after seat position has been adjusted and under 6mm in terms of the up-down direction. When doing so, it is fine if the hip point is within the range of diagram 6. However, in cases where this condition cannot be met, the hip point is to be made as close to this range as possible.

Diagram 6

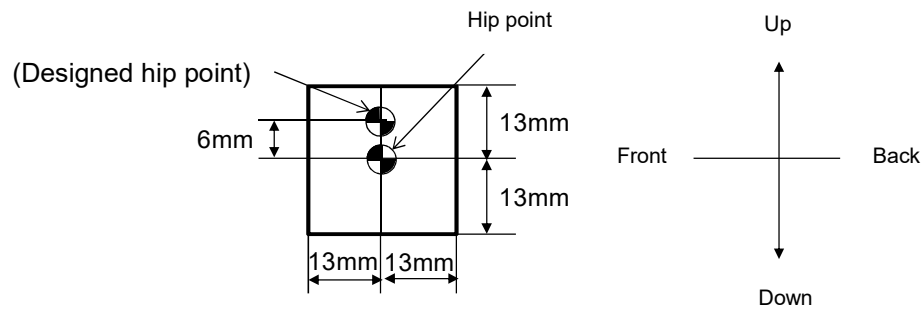

- (2) Set the pelvis angle to a range of $22.5^{\circ} \pm 2.5^{\circ}$. (Diagram 7)
- (3) Set head angle to a range of $\pm 0.5^{\circ}$ horizontally. If when doing so the head angle cannot be set within the appropriate range, the position of the dummy's upper body is to be readjusted within the ranges stipulated in (1) and (2), in the order of hip point then pelvis. In cases where, even after these readjustments, the head angle cannot be set within the range stipulated in this section, the neck bracket is to be moved get the head angle within the appropriate range. (Diagram 7)
- (4) In cases where the position of a dummy's upper body has been adjusted as stipulated in (1) to (3) and the pelvis angle is not within the range stipulated in (2), the dummy's upper body posture may be moved forward or backward within a range of $\pm 2.5^{\circ}$ to adjust the pelvis angle. In cases where, as a result of these adjustments, the head angle no longer falls within the range stipulated in (3), the neck bracket is to be moved to adjust the head angle so that it is as close to level as possible.

Diagram 7

The hip-point position shall be a point 46.5mm horizontally forward from pelvic angle gauge hole, 65.0mm vertically below, when the dummy pelvic angle is set to a horizontal position.

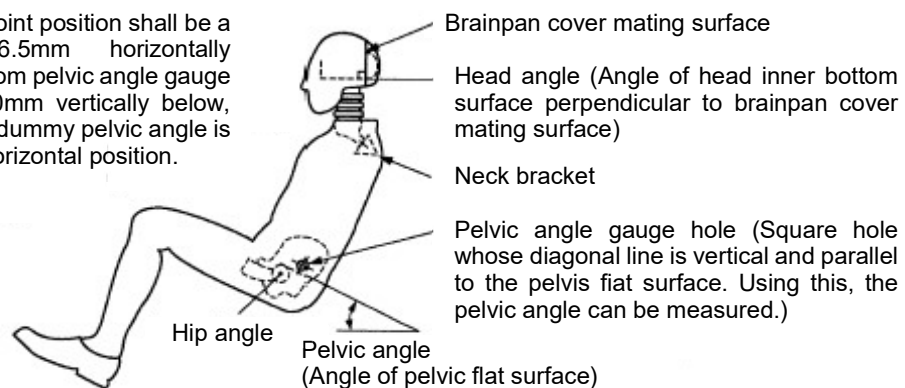

5. Set arm and hand positions

- (1) Set the thumbs on the steering wheel rim. The position of the palms should be on a line that

passes through the center of the steering wheel, with the top of the hands facing towards the exterior of the vehicle. Furthermore, the left and right armpits are to be closed.

- (2) Affix the thumbs on the steering wheel with tape. The tape should be drafting tape approximately 12mm in width.

6. Reset the positions of the legs

If the legs come out of position when setting the position of the upper body, legs should be returned to the position set according to the stipulations of section 2.

7. Affix pressure sensitive paper to the chest of the chest of the driver seat dummy.

In order to confirm secondary collision between the chest of the driver seat dummy and the steering rim, pressure sensitive paper is to be affixed to the skin of the driver seat dummy's chest as a trial with the following method in the short term. (Applies to vehicles with a steering angle over 32°.)

- (1) Pressure sensitive paper (pressure measurement film) is to possess the ability to measure between 2.5MPa and 10MPa. The range for evaluating secondary collisions between the steering wheel and the dummy's chest is 135mm vertically by 200mm horizontally, with the pressure sensitive paper guaranteeing dimensions of at least those found in diagram 8. As there is no cover for the adjustment hole on the dummy's chest, the hole is to be left open as in the diagram.

Diagram 8 - Secondary collision evaluation range and dummy chest adjustment hole dimensions

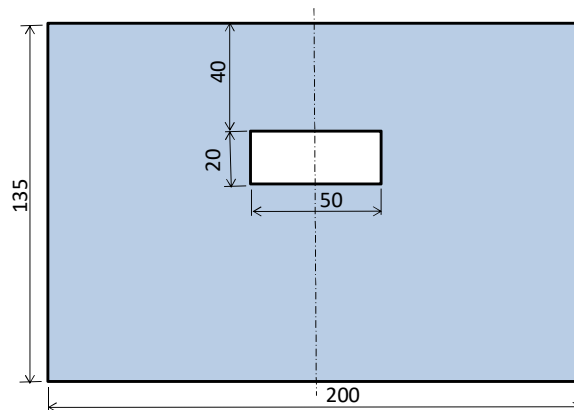

- (2) Check with others present that there is no coloration on the pressure sensitive paper before applying it to the dummy.
- (3) In cases where the hands and arms must be moved in order to affix the pressure sensitive paper, move the hands and arms in a manner that moves the upper body as little as possible and perform the process of rolling up the dummy's clothing.
- (4) Pressure sensitive paper (depending on the type, in a state with 2 sheets layered) is to be position along the skin of the dummy's chest as bilaterally symmetrical as possible from the lower neck to the upper side of the chest ribs as shown in diagram 9, with the adjustment hole in the dummy's chest completely visible. Pressure measurement film is to be secured in place with tape at the upper and lower ends of the film.

- (5) Check with others present that there is no coloration on the pressure measurement film, as well as take a photograph confirming that there is no coloration on the pressure measurement film.
- (6) Return the dummy's clothing and appendages to their original positions once the process is complete.

Diagram 9 - Positioning of pressure sensitive paper



HOW TO LOAD THE PASSENGER SEAT DUMMY

Dummies shall be loaded into the passenger seat of test automobiles following the steps below.

1. Seat position

- (1) Match the dummy's left, right, and center with the designed seat center.
- (2) Place the dummy's torso against the seat back, and match the hip point as closely as possible with the designed hip point after adjusting seat position.

2. Setting leg positions

- (1) First match both knees to the initial interval in the diagram. However, these dimensions do not prescribe the final position of the knees. Furthermore, this shall not apply to cases where the space between the knees and the instrument panel is not over 10 mm, cases where the space between the knees cannot be set to the stipulated interval, and cases where the knees cannot be set perpendicular due to the shapes of the instrument panel, floor, and toe board.

Diagram 8

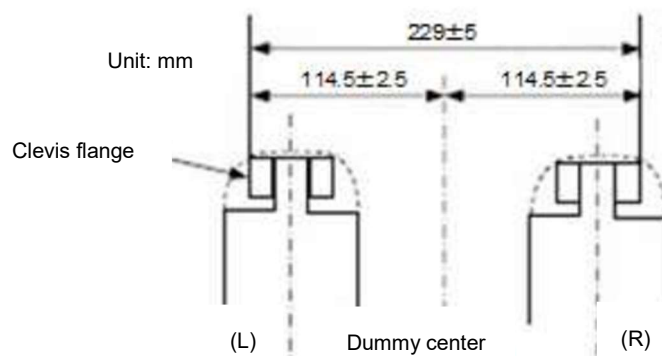

- (2) Adjust the right and left femur and tibia so the planes formed by each of them are perpendicular to each other.
- (3) Place the femurs in a state in contact with the surface of the seat cushion, in a position with the leg as far as possible from front end of the seat cushion. (See diagram 9)

Diagram 9



(4) Place the foot and the tibia at a right angle, then lower the leg until the foot reaches the floor without changing the angle of the femur (See diagram 10).

Diagram 10



(5) Rotate the foot with the heel touching the floor so that the toes touch the floor as much as possible. (See diagram11)

Diagram 11



(6) In cases where the foot does not touch the floor, either place the calf in contact with the front end of the seat cushion or lower the foot until the back of the foot comes into contact with the interior upholstery and the foot is as level as possible with the floor (See diagram 12).

Diagram 12



(7) In cases where the feet interpose with protrusions in the body of the vehicle, rotate the direction of the toes as little as possible to the left or right while maintaining the interval between the knees in

order to avoid interposition. If the feet are still in the way even after doing this, rotate the femurs to eliminate or minimize the obstruction and prevent the feet from being in the way as much as possible. Finally, in cases where the space between the lower legs and the instrument panel is under 10 mm, conduct seat rail adjustments forwards or backwards to adjust the space to at least 10 mm.

3. Initial position of arms and hands

- (1) Upper arms are to be placed against the seat back, so that they also touch the upper body.
- (2) The lower arms and hands are to be placed along the outside of the femurs.

4. Setting the position of the upper body

- (1) The dummy's hip point on the external side of the vehicle is to match a position that is left as-is in terms of the front-back direction, from the designed hip point after seat position has been adjusted and under 6mm in terms of the up-down direction. When doing so, it is fine if the hip point is within the range of diagram 13. However, in cases where this condition cannot be met, the hip point is to be made as close to this range as possible.

Diagram 13

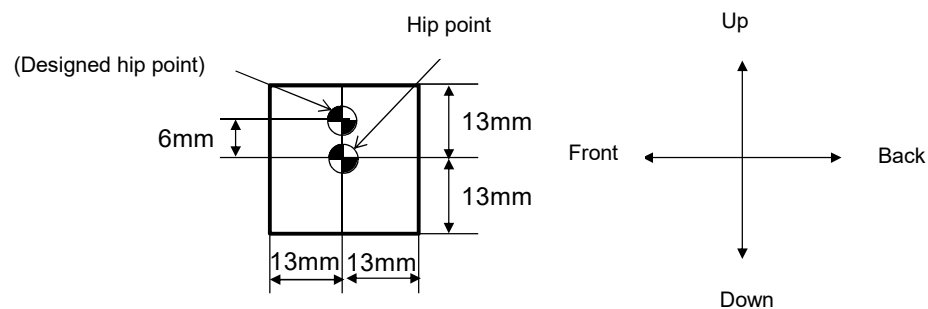

- (2) Set the pelvis angle to a range of $20.0^\circ \pm 2.5^\circ$.
- (3) Set the head angle to a range of $\pm 0.5^\circ$ horizontally. If when doing so the head angle cannot be set within the appropriate range, the position of the dummy's upper body is to be readjusted within the ranges stipulated in (1) and (2), in the order of hip point then pelvis. In cases where, even after these readjustments, the head angle cannot be set within the range stipulated in this section, the seat back angle is to be adjusted get the head angle within the appropriate range.
- (4) In cases where the position of a dummy's upper body has been adjusted as stipulated in (1) to (3) and the pelvis angle is not within the range stipulated in (2), the dummy's upper body posture may be moved forward or backward within a range of $\pm 2.5^\circ$ to adjust the pelvis angle. In cases where, as a result of these adjustments, the head angle no longer falls within the range stipulated in (3), the neck bracket is to be moved to adjust the head angle so that it is as close to level as possible.

5. Set arm and hand positions

- (1) The upper arms are to be placed as closely in contact as possible with the seat back and touching the torso.

- (2) The lower arms and hands are to be placed as closely in contact as possible with the sides of the femurs, with the little fingers lightly touching the seat cushion.
- (3) In cases where setting the hands and arms as stipulated in (1) and (2) interferes with the door trim, the arm may be placed upon the armrest beside the door trim in order to avoid interference.

6. Reset the position of the legs

In cases where the legs moved out of position while setting the position of the upper body, return the legs to the position stipulated in section 2.

MEASUREMENT PROCEDURE FOR DESIGNED HIP POINT AND ACTUAL TORSO ANGLE IN SEATED POSITION IN THE AUTOMOBILE

1. Purpose

The process stipulated in this enclosure is for measuring the designed hip point position (referred to hereafter as “hip point”) and actual torso angle in the seated position of one or more automobiles.

2. Definitions

- 2.1 “Three-dimensional mannequin”** refers to the device used to measure the hip point and actual torso angle. This device will be described in an appendix. The length of the femurs and lower legs will be adjusted to 401 mm and 414 mm each.
- 2.2 “Hip point”** refers to the rotation center of a three-dimensional mannequin’s torso and femurs when attached to an automobile based on section 3. The position of the hip point between the hip point side buttons found on both sides of the three-dimensional mannequin. After it has been set once using the process stipulated in section 3, the positional relationship of the hip point and seat cushion structure is to be viewed as fixed, with the hip point moving along with seat when it is adjusted.
- 2.3 “Torso line”** refers to the center line when the three-dimensional mannequin’s probe is placed in the rearmost position.
- 2.4 “Actual torso angle”** refers to the angle between the torso line and the perpendicular line passing through the hip point measured using the three-dimensional mannequin’s back angle protractor.
- 2.5 “Occupant center plane”** refers to the center plane of the three-dimensional mannequins placed in the designated seated positions. This is depicted by the hip point coordinates on the Y-axis. When referring to individual seats, the center plane of the seat will be the same as the occupant center plane. When referring to other seats, use the occupant center plane determined by the automobile manufacturer.
- 2.6 “Three-dimensional coordinate system”** refers to the system stipulated in appendix 2.
- 2.7 “Reference point marks”** refers to the physical points on the vehicle (holes, surfaces, marks, or notches) determined by the automobile manufacturer.
- 2.8 “Vehicle measurement posture”** refers to an automobile’s position as determined by the coordinates of the reference point marks in the three-dimensional coordinate system.

3. Measurement procedure for the hip point and actual torso angle

- 3.1** The test automobile is, at the automobile manufacturer’s discretion, to be kept at a temperature of $20\pm 10^{\circ}\text{C}$, with the seat material confirmed to have reached room temperature. If no one has ever sat in a seat that is to be examined, a person or device weighing 70 to 80 kg is to be sat upon the seat for 1 minute 2 times to make the cushion and bag flexible. Do not place any weight upon the entire seat assembly for at least 30 minutes before attaching the three-dimensional mannequin.

- 3.2** Test automobiles are to be placed in the measured posture defined in section 2.8.
- 3.3** In cases where seats can be adjusted, seats are to be placed in the rearmost normal driver and passenger positions determined by the automobile manufacturer. When doing so, only front-back adjustments of the seat may be considered, excluding seat travel used for intents other than the normal driver and passenger position. In cases where there are other seat adjustment modes (vertical, angle, seat back, and so on), these are to be adjusted to the position determined by the automobile manufacturer later. In cases where there are suspension seats, set the vertical position to the normal driver and passenger positions determined by the automobile manufacturer and fix them firmly in place.
- 3.4** The range of the seating position the three-dimensional mannequin comes into contact with is to be covered in muslin cotton of sufficient size and appropriate fabric (18.9threads/cm² and 0.228kg/m), knitted fabric possessing the same qualities, or non-woven fabric.
- 3.5** The seat back assembly of the three-dimensional mannequin is to be placed so that the occupant center plane aligns with the center plane of the three-dimensional mannequin. In cases where the position of the three-dimensional mannequin is too close to the outside, and the three-dimensional mannequin is prevented from being level by the end of the seat, the three-dimensional mannequin may be moved towards the inside from the occupant center plane.
- 3.6** The feet assemblies and lower leg assemblies are to be attached individually or using a T bar lower leg assembly. They are to be parallel to the line passing through the hip point side buttons, and must be at a right angle to the front-back direction vertical center plane of the seat.
- 3.7** The position of the three-dimensional mannequin's feet and legs are to be adjusted as follows.
- 3.7.1** Feet are to be placed upon the floor, with the feet assemblies and leg assemblies both moved forward as necessary so that the feet are in a natural position between the control pedals. If possible, the distance between the three-dimensional mannequin's center plane and left foot and the distance between its right foot are to be made the same. The level confirming the horizontal position of the three-dimensional mannequin is, as necessary, to be made level by readjusting the seat pan or adjusting the leg and feet assemblies to the rear. The line passing through the hip point side buttons is to be kept at a right angle to the front-back direction vertical center plane of the seat.
- 3.7.2** In cases where the left and right legs cannot be kept parallel, and the left leg cannot be supported by a structure, the left leg is to be moved until it is supported. The focal point is to be level and vertical to the front-back direction vertical center plane of the seat and kept in this state.
- 3.8** Apply lower leg weights and femur weights to make the three-dimensional mannequin level.
- 3.9** Lean the back pan forward until it reaches forward stop, then separate the three-dimensional mannequin from the seat back using a T bar. Readjust the position of the three-dimensional mannequin using the method stipulated below.
- 3.9.1** Use the following procedure if the three-dimensional mannequin is to be moved to the rear. Slide the three-dimensional mannequin back until the weight on the forward part of the T bar is no longer needed (until the seat pan comes into contact with the seat back). Readjust the position of the lower legs as necessary.

3.9.2 Use the following procedure if the three-dimensional mannequin is not to be moved to the rear. Apply weight to the level rear of the T bar and slide the three-dimensional mannequin back until the seat pan comes into contact with the seat back (see Attachment 1 diagram 2).

3.10 Apply a load of $100\pm 10\text{N}$ to the back pan assembly of the three-dimensional mannequin at the point of intersection between the T bar housing and the hip angle protractor. The direction in which the load is applied is to be along the line passing through the aforementioned point of intersection and a point directly above the femur bar housing (see Attachment diagram 2). Next, carefully return the back pan to the seat back. Take care to ensure that the three-dimensional mannequin does not move forward during the remaining portion of the procedure.

3.11 Attach buttocks weight to the left and right hip point pivots, and then alternately attach individual torso weights to the torso weight hanger. Keep the three-dimensional mannequin level.

3.12 Lean the back pan forward to release pressure on the seat back. Sway the three-dimensional mannequin by means of making an arc of 10° (5° to each side in the front-back direction of the vertical center plane) for three complete cycles, thus eliminating friction accumulated between the three-dimensional mannequin and the seat.

During swaying, the prescribed horizontal and vertical line states of the three-dimensional mannequin's T bar may shift. Therefore, adequate weight must be applied in a direction during swaying to keep the T bar in place. Take care that when restraining the T bar and swaying the three-dimensional mannequin unexpected external weight is not applied in the vertical or front-back direction.

There is no need to restrain or keep the three-dimensional mannequin's feet in place at this stage. If the position of the feet change, leave them in that posture.

Take great care in returning the back pan to the seat back, and check whether the 2 levels are in the zero position or not.

In cases where the feet moved during the act of swaying the three-dimensional mannequin, readjust their position in the following manner.

Lift each foot in alternation from the floor so that the feet will not move any further. Both feet should be able to rotate freely during this action, and no weight is to be applied forward or laterally. In cases where each foot will be returned to the position it was lowered into, the heel is to touch the structure designed for that purpose.

Confirm that the lateral level is in the zero position. If necessary, apply sufficient lateral weight to the top of the back pan to level the three-dimensional mannequin's seat pan on the seat.

3.13 Conduct the following procedure while keeping the T bar in place to ensure that the three-dimensional mannequin does not move forward on the seat cushion.

(a) Return the back pan to the seat back.

(b) Apply horizontal rear weight not greater than 25 N at the same height as the center of the torso weights to back angle bar, repeatedly applying and removing the weight in alternation until it can be confirmed with the hip angle protractor that a stable position has been reached after the weight has been removed. Take care that external weight is not applied to the three-dimensional mannequin is

not applied from below or laterally. If levelling adjustments for the three-dimensional mannequin become necessary once again, rotate the back pan forward and, upon levelling it once more repeat the procedures of section 3.12.

3.14 Conduct all measurements.

3.14.1 Measure the actual measured position of the hip point based on the three-dimension coordinate system.

3.14.2 Place the probe in a completely rear position and read the actual torso angle on the three-dimensional mannequin's back angle protractor.

3.15 In cases where reimplementation of the attaching the three-dimensional mannequin is desired, no weight must be applied to the seat assembly for at 30 minutes before reimplementation. The three-dimensional mannequin must not be left applying weight to the seat assembly for a time longer than that needed to implement the test.

3.16 In cases where the driver seat and passenger seat are deemed to be the same (bench seats, seats with identical designs, and so on), only a single hip point and a single "actual torso angle" need to be measured. Place the three-dimensional mannequin described in Attachment 1 in the driver seat as a representative.

4. How to find the AF05 hip point

The front-back direction and up-down direction dimensions of the hip point of male 50th percentile dummies shall be (X_{AM50} , Z_{AM50}), and the front-back direction and up-down direction dimensions of the hip point of female X percentile dummies shall be (X_{AF05} , Z_{AF05}). XSCL shall be defined as the hip point in male 50th percentile dummies and the horizontal distance of the foremost point on the seat cushion (see diagram 1). Measure the hip point of female 5th percentile dummies according to the following formula.

$$X_{AF05} = X_{AM50} + (93 - 0.323 \times XSCL)$$

$$Z_{AF05} = Z_{AM50}$$

X is the vehicle's rear direction, and Z is the vehicle's upward direction.

Diagram 1

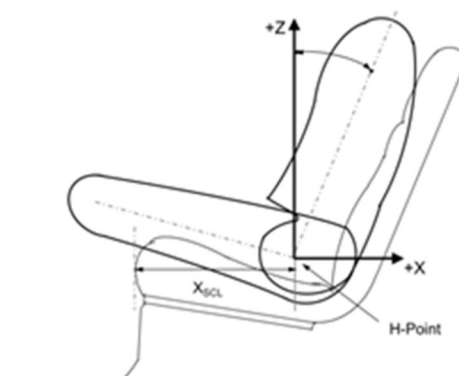

ATTACHMENT 2 ANNEX 1 : THREE-DIMENSIONAL MANNEQUIN EXPLANATIONS^{*note2}

1. Back and seat pans

The back pan and seat pan are composed of reinforced plastic and metal. They emulate the torso and femurs of the human body, and are connected mechanically by a hinge at the hip point. In order to measure the actual torso angle, a protractor is fixed in place with a probe attached by a hinge at the hip point. The adjustable femur bar attached to the seat pan determines the center line of the femurs, which in turn serves as the base line of the hip angle protractor.

2. Body and leg elements

While the lower legs are connected to the seat pan assembly by a knee joint T bar, this T bar is a lateral extension of the adjustable femur bar. A protractor has been built into the lower legs in order to measure knee angle. A scale has been attached to the shoe and feet assemblies in order to measure foot angle. 2 levels determine the vertical and horizontal position of the mannequin. A center of gravity corresponding to the body element weight has been attached to produce an equivalent load to a male of 76 kg in weight sitting in the seat. All of the joints of the three-dimensional mannequin must be checked to ensure that they can move freely without producing considerable friction.

Diagram 1 names of three-dimensional mannequin parts

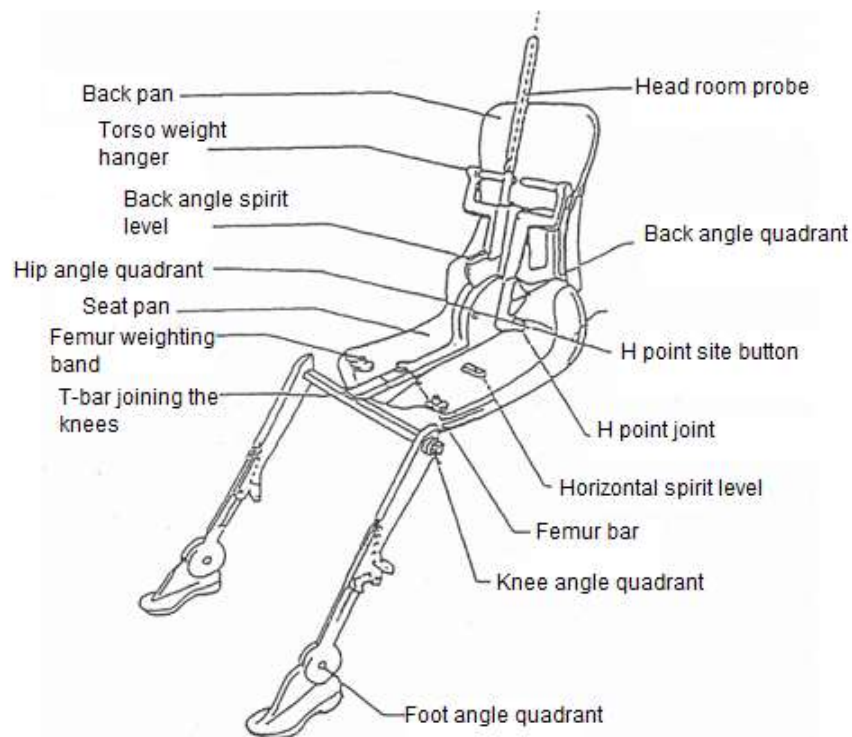

^{note2} For details on the construction of three-dimensional mannequins, refer to SAE, 400 Commonwealth Drive, Warrendale, Pennsylvania 15096, U.S.A.
This device suits ISO 6549-1999 standards and the terms denoted in SAE J826.

Diagram 2 Dimensions and weight distribution of 3-DH measurement elements

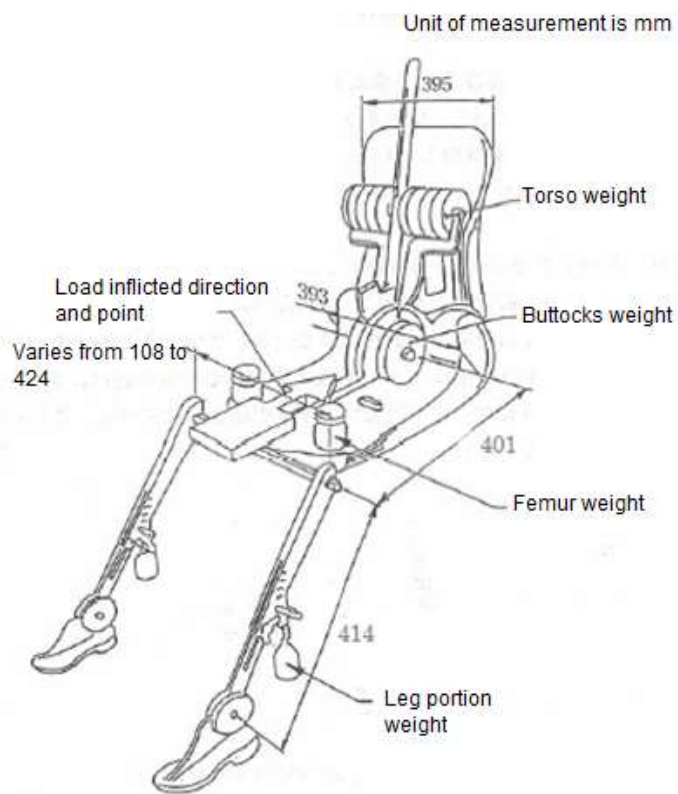

ATTACHMENT 2 – ANNEX 2 : THREE-DIMENSIONAL COORDINATE SYSTEM

1. The three-dimensional coordinate system is regulated by three orthogonal planes determined by the automobile manufacturer (see diagram).^{*Note3}
2. Vehicle measurement posture is determined by placing the automobile on the installation surface in such a manner that the coordinates of the reference point marks match the values determined by the automobile manufacturer.
3. Hip point coordinates are determined based upon the reference point marks determined by the automobile manufacturer.

Diagram - Three-dimensional coordinate system

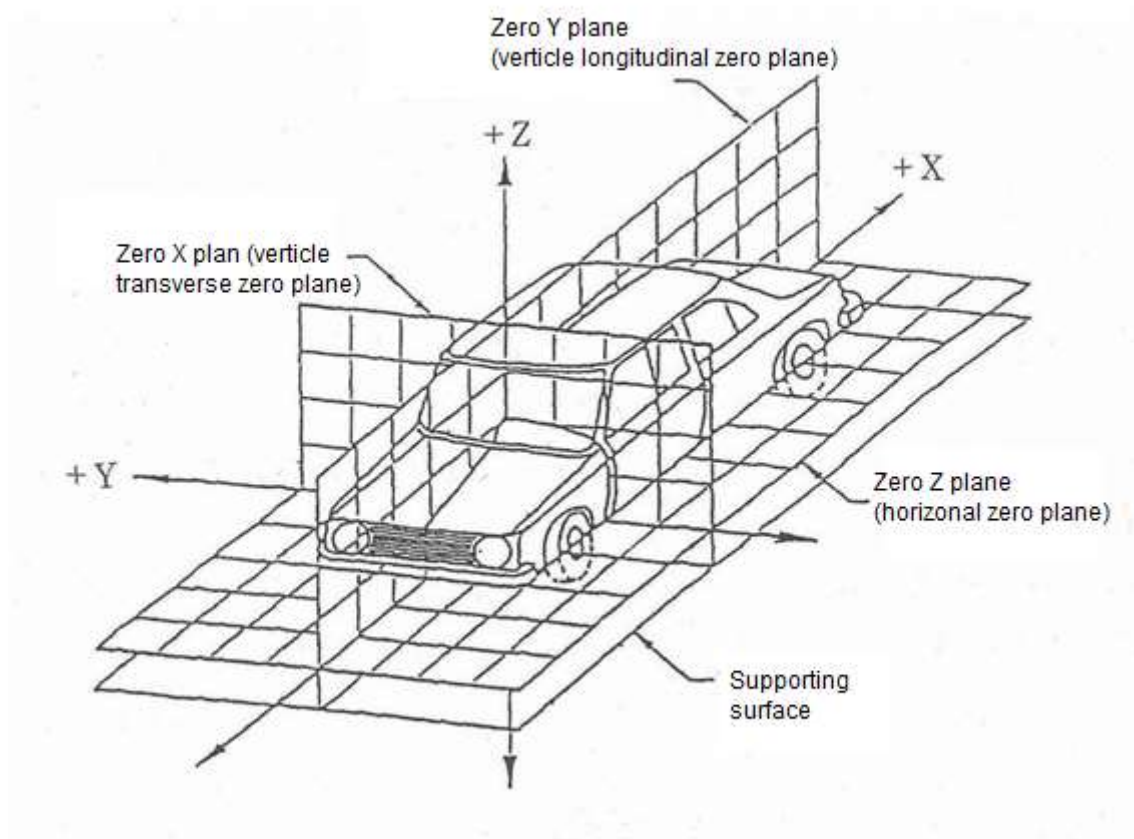

^{note3} This coordinate system complies with ISO standards 4130 and 1978.

HYBRID III DUMMY 50TH PERCENTILE INSPECTION METHOD

1. Inspection method and requirements

In cases where it is necessary to inspect the features of each part of a dummy in accordance with sections 1.2 to 1.6, the dummy may be dismantled and put together. Furthermore, the measurement of structural dimensions in section 1.1 are to be completed after all inspections of sections 1.2 to 1.6 have been completed and the dummy has been assembled back into its proper state. Tape may be used with the intent of maintaining the dummy's posture when measuring the dummy's dimensions and features.

1.1 Structural dimensions

The dimensions of each part when measuring dummy part dimensions are to be as indicated in diagram 1.

Diagram 1 - Hybrid III structural dimensions

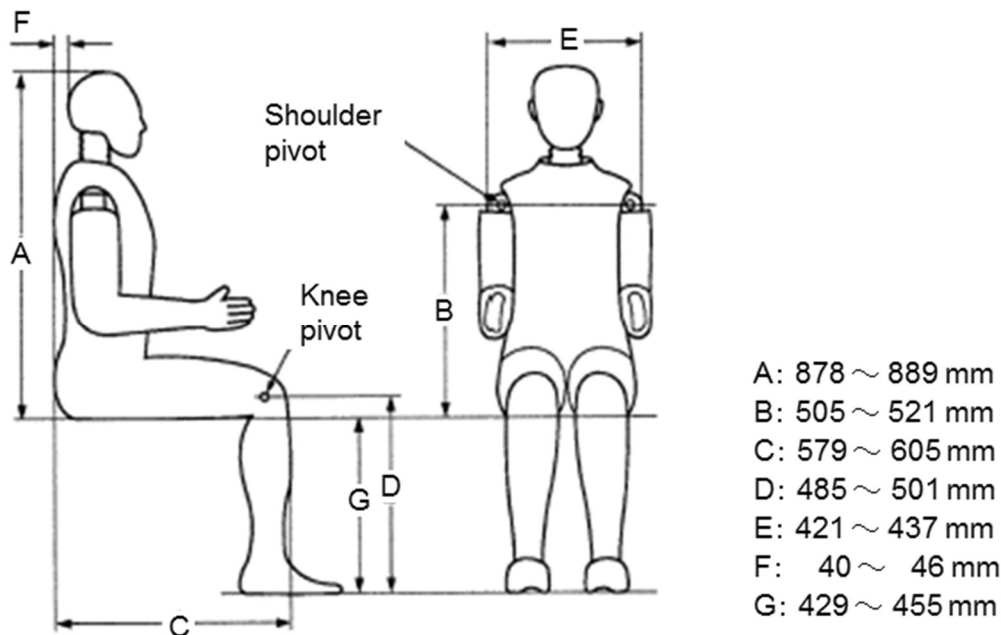

1.2 Head features

When conducting inspection tests following the procedure below, the maximum resultant acceleration value when the head is falling is to be between $2,205\text{m/s}^2$ and $2,695\text{m/s}^2$, and the maximum value of the waveform that occurs after the main waveform (referred to as the maximum waveform) on a resultant head acceleration/time curve is to be under 10% of the maximum value of the main waveform. Furthermore, the maximum value of the left-right acceleration is to be under 147m/s^2 .

(1) The inspected head is to be stored for over 4 hours in environment conditions maintained such that temperature is between 18.9°C and 25.6°C , and humidity is between 10% and 70%.

- (2) Suspend the head so that the lowest point of the forehead is 13 ± 1 mm lower than the lowest point of the dummy's nose with the head lifted from a height of 376 ± 3 mm as depicted in diagram 2. When it is dropped on an iron plate of at least 50 mm thickness with a surface roughness between 0.0002mm (ms) and 0.002mm (ms), measure the 3 axials (front-back, left-right, and up-down directions) acceleration and find the maximum resultant acceleration value. When doing so, attach a Neck Transducer substitute structure to place the head in a state as if it were actually attached.
- (3) When inspecting the same head successively, an interval of at least 3 hours in the environmental conditions stipulated in (1) between tests.

Diagram 2 - Head feature tests

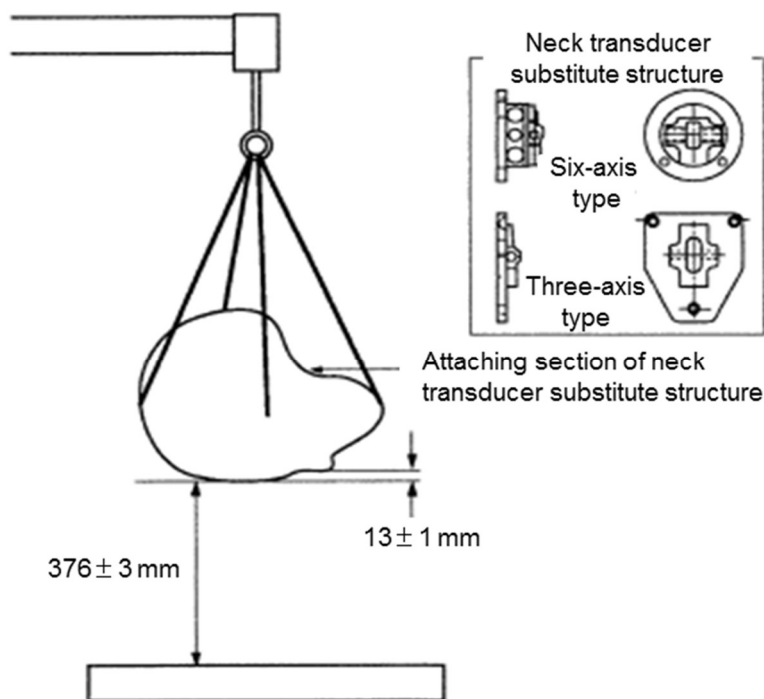

1.3 Neck features

When conducting inspection tests following the procedure below, curve side (the side the neck contracts on) features and expansion side (the side the neck extends on) are each depicted in the following table.

Curve side features	<p>① Plane D in diagram 3 rotates in an angle between 64° and 78° between 57ms and 64ms after collision (the moment of contact between collision surface and the buffer come into contact being the time reference point), with the D plane rotation from the initial rebound crossing 0° between 113ms and 128ms.</p> <p>② The maximum moment value measured by the neck measurement instruments is to occur between 47ms and 58ms, and between within a range between 88Nm and 108Nm. Furthermore, the positive moment (the moment where direction is the same as direction of pendulum rotation) is to first decay to 0Nm between 97ms and 107ms after collision.</p>
Expansion side features	<p>① Plane D in diagram 4 rotates in an angle between 81° and 106° between 72ms and 82ms after collision (the moment of contact between collision surface and the buffer come into contact being the time reference point), with the D plane rotation from the initial rebound crossing 0° between 147ms and 174ms.</p> <p>② The maximum moment value measured by the neck measurement instruments is to occur between 65ms and 79ms, and between within a range between -80Nm and -53Nm. Furthermore, the positive moment (the moment where direction is the same as direction of pendulum rotation) is to first decay to 0Nm between 120ms and 148ms after collision.</p>

Diagram 3 - Neck curve side features

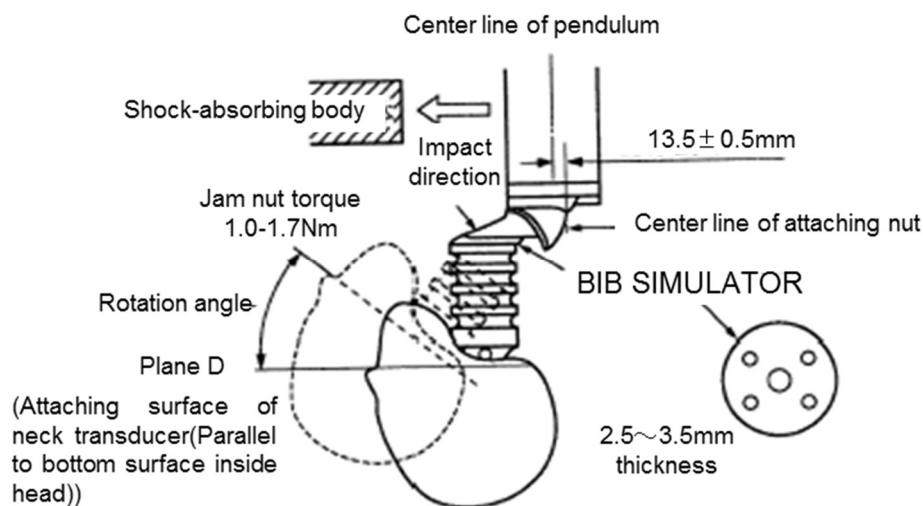

Sample rotation angle measurement methods

- Affix a displacement sensor to measure and calculate
- Film analysis using high-speed photography.

Diagram 4 - Neck expansion side features

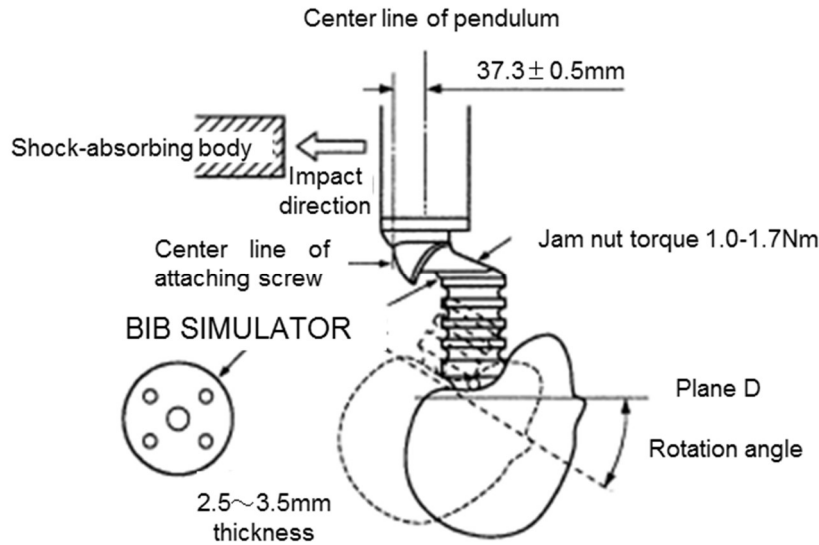

- (1) The inspected neck is to be stored for over X hours in environment conditions maintained such that temperature is between 20.6°C and 22.2°C, and humidity is between 10% and 70%.
- (2) Before inspection, tighten the jam nuts of the neck cable with a torque between 1.0Nm and 1.7Nm.
- (3) Attach the neck and head to the pendulum as indicated in diagram 5 with face facing the direction of collision (curve side inspection) and the opposite direction (expansion side inspection). When doing so, attach a bib simulator (see diagrams 3 and 4) to simulate an actual attached state, with plane D being perpendicular to the center line of the pendulum. However, a head for inspection purposes only with an inspection displacement sensor attached may be used for the head.
- (4) The pendulum is to be swung to cause collision at speeds of between 6.89m/s and 7.13m/s for curve side inspections, and between 5.95m/s and 6.18m/s for expansion side inspections, with the rotation angle and moment at these times measured and calculated.

Neck moment is calculated according to the following formula.

- ① If the measurement instrument is 3 axial

$$M = M_y - 0.008763(m) \times F_x$$

- ② If the measurement instrument is 6 axial

$$M = M_y - 0.01778(m) \times F_x$$

In this case,

M is neck moment (unit: Nm)

M_y is the neck measurement instrument moment (unit: Nm)

F_x is the x axial force of the neck measurement instrument (unit: N)

- (5) In curve inspections, the deceleration of the pendulum that occurs at the time of collision corresponds to the elapsed time post collision indicated in the left column of table A, with each range value in the right column of table A and the decaying deceleration/time curve of the pendulum first crossing 49m/s² between 34ms and 42ms. Furthermore, in expansion inspections the deceleration of the pendulum that occurs at the time of collision corresponds to the elapsed

time post collision indicated in the left column of table B, with each range value in the right column of table B and the decaying deceleration/time curve of the pendulum first crossing 49m/s^2 between 38ms and 46ms.

Diagram 5 - Neck feature inspections

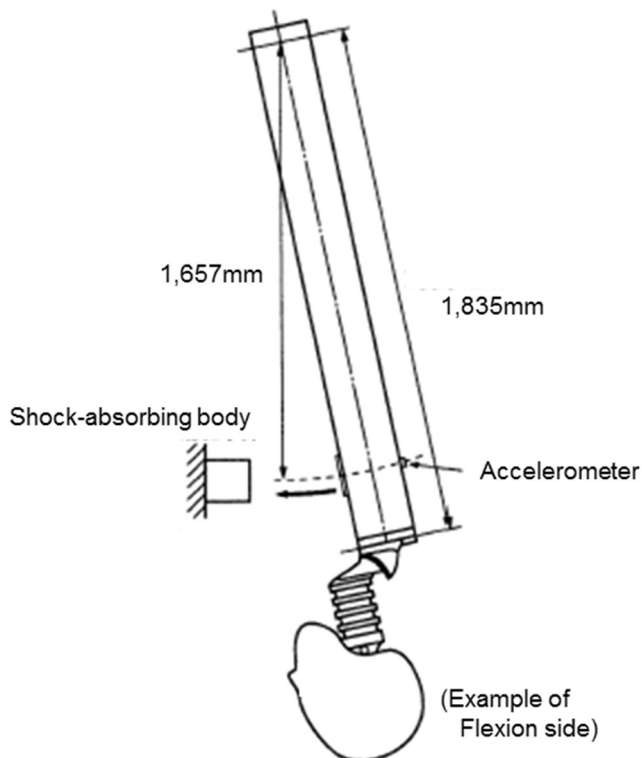

Table A

Time (ms)	Deceleration range (m/s^2)
10	220~270
20	172~222
30	122~182
More than 30	Less than 285

Table B

Time (ms)	Deceleration range (m/s^2)
10	168~208
20	137~187
30	107~157
More than 30	Less than 216

(6) When using the same neck etc., for the test successively, an interval of at least 30 minutes in the environmental conditions stipulated in (1) must left between tests.

1.4 Chest features

When applying impact to the chest with an impact device according to the following procedures, the maximum value of the impulsive force occurring the impact element is to be between 515daN and 589daN, and the maximum displacement value of the sternum in relation to the vertebral column is to be between 63mm and 73mm. Furthermore, internal hysteresis during impact is to be within a range of 69% and 85%.

(1) The inspected chest is to be stored for at least 4hours in environment conditions maintained at a temperature between 20.6°C and 22.2°C , and humidity is between 10% and 70%.

(2) As indicated in the diagram 6, sit the dummy on a level surface without its back or elbows resting

against anything, and with the shoulder and elbow joints lightly tightened so that the upper arms thrust forward, with the pelvis angle adjusted between $13^{\circ} \pm 2^{\circ}$. In this situation the dummy may be dressed in a shirt and pants as stipulated in 3.2.9.2(3).

Diagram 6 - Chest feature inspection

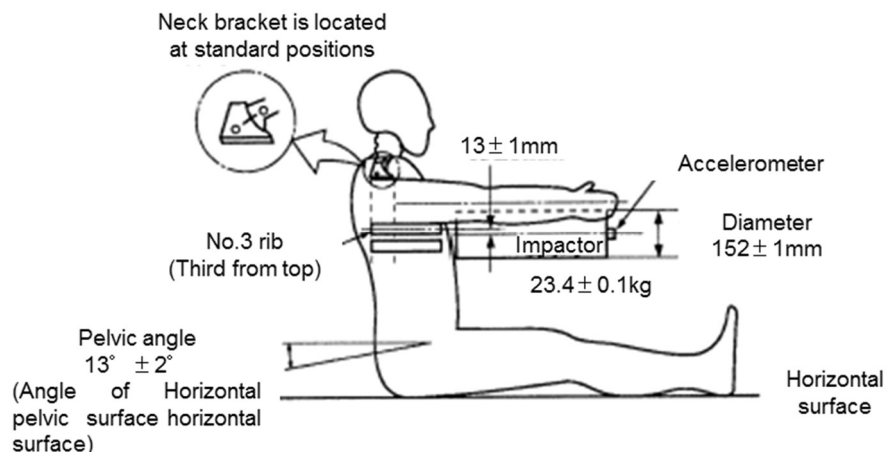

- (3) Adjust the positional relationship between the impact device and rib no. 3 in such a manner that the longitudinal direction center line extending from the impact device is 13.0 ± 1.0 mm lower than the horizontal center line of rib No. 3 on the dummy's center plane.
- (4) Collide the impact device with the chest at a speed between 6.59m/s and 6.83m/s, with the deceleration that occurs at the rear end of the impact device at this time the displacement of the sternum in regards to the dummy's vertebral column (measured with a displacement gage attached inside the sternum), then measure and calculate the impulsive force occurring in the impact device (the product of the impact device's mass and deceleration), and the hysteresis (the comparison (A/B) of the area A between the load of the force displacement curve and the unloaded portion, and the area B below said curve's loaded portion (see diagram7)).
- (5) When inspecting the same chest successively, it must be left for an interval of at least 30 minutes in the environmental conditions stipulated in (1) between tests.

Diagram 7 -Chest feature inspection load/displacement curve

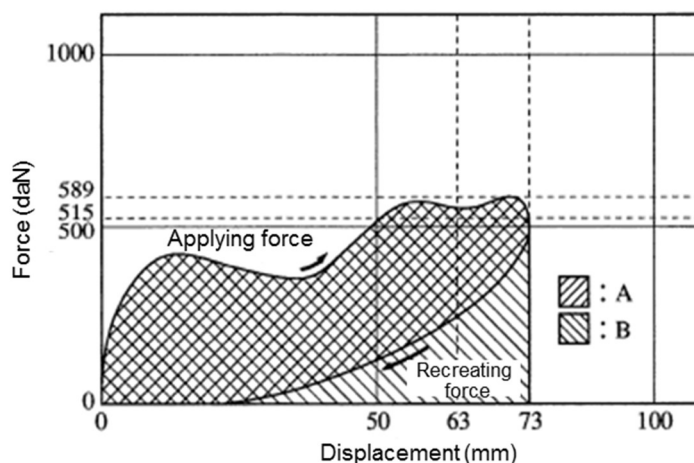

1.5 Leg features

When applying impact to the right and left knees of the legs with an impact device according to the following procedures, the maximum value of the impact load occurring in the impact device (a cylinder with the portion applying impact $76\pm 1\text{mm}$ in diameter. In order to measure the acceleration of the impact device that occurs along the center line of the cylinder's longitudinal direction, an accelerometer is to be attached to the surface of the impact device on the side opposite the side of impact in such a manner that it overlaps this same line. Furthermore, the mass of the impact device is to be $5.0\pm 0.1\text{kg}$ including the accelerometer.) is to be within 471daN and 578daN (See diagram 8).

- (1) The inspected legs are to be stored for at least 4 hours in environment conditions maintained such that temperature is between 18.9°C and 25.6°C , and humidity is between 10% and 70%.
- (2) Adjust the position of the impact device so that, when the impact device comes into contact with the knees in a level state, the height of the impact device's longitudinal direction center line is the same as the height of the center line of the knee pivot bolts on a vertical plane passing through the femur's center line.
- (3) Collide the impact device with the knees at a speed between 2.07m/s and 2.13m/s , with the deceleration that occurs at the rear end of the impact device at this time, and the impulsive force occurring in the impact device (the product of the impact device's mass and deceleration) measured and calculated.
- (4) When inspecting the same legs successively, an interval of at least 30 minutes in the environmental conditions stipulated in (1) must left between tests.

Diagram 8 - Leg feature test

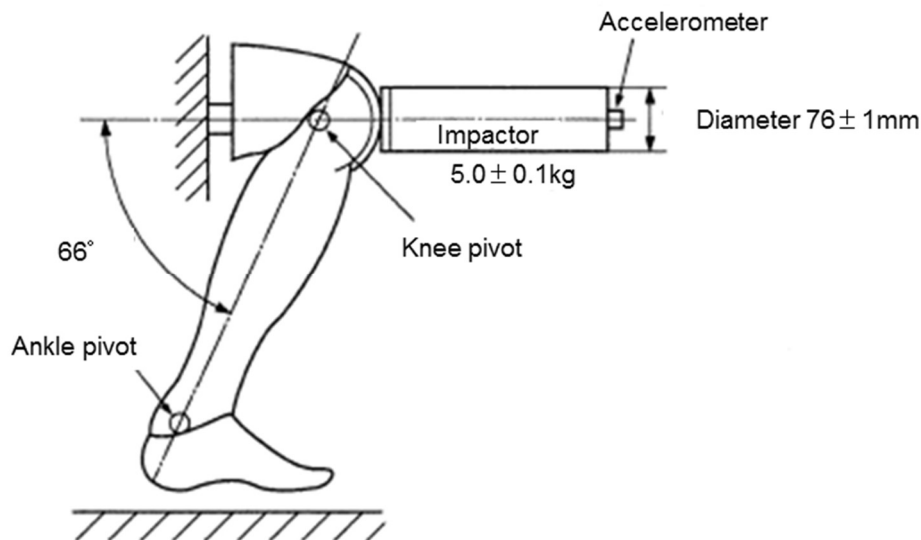

1.6 Femur bend feature

When rotating each femur upwards vertically according to the following procedures as indicated in diagram 9, the femur torque when rotated 30° from initial level position is to be below 95Nm , with 203Nm torque between 40° and 50° .

- (1) The inspected femurs are to be stored for at least 4 hours in environment conditions maintained

such that temperature is between 18.9°C and 25.6°C, and humidity is between 10% and 70%.

(2) Remove the legs and upper body above the lumbar, including the abdomen, from the dummy.

(3) Set the dummy on the platform and, while keeping the upper surface of the pelvis level, fix the pelvis in place with a pelvis fixture tool, and the lumbar in place with a lumbar fixture tool.

Furthermore, affix a tool for loading stress to the axial rotation joints of the femurs.

(4) While keeping the bolts attaching the tool for loading stress level, rotate the tool upwards along the longitudinal direction vertical plane of the tool until it reaches a torque of 203Nm. The rotation angle speed is to be between 5° and 10° per second. Record the torque and rotation angle at this time.

(5) When inspecting the same femurs successively, must left between tests for an interval of at least 30 minutes in the environmental conditions stipulated in (1).

Diagram 9 - Femur bend feature test

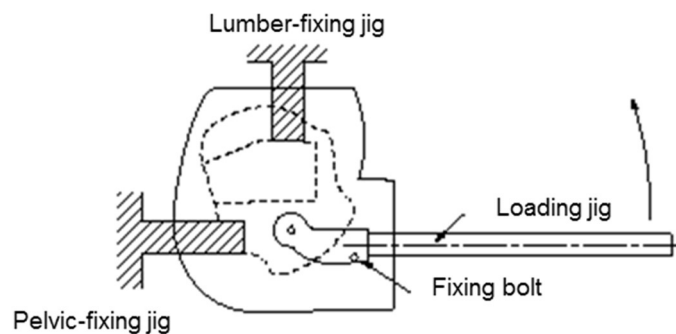

1.7 Leg and feet features

1.7.1 Upper leg impact test

1.7.1.1 Test procedure

1.7.1.1.1 Each assembly is to be stored for 4 hours prior to testing in a state with a temperature of $22\pm 3^{\circ}\text{C}$ and comparative humidity of $40\pm 30\%$. This does not include the time needed to reach this steady state.

1.7.1.1.2 Prior to testing, the impact surface of the upper legs and surface of the impact device are to be cleaned with isopropyl alcohol or a similar substance and freed of dust with talc.

1.7.1.1.3 Adjust the accelerometer on the impact device so that the measurement axis is parallel to the direction of impact connecting with the foot.

1.7.1.1.4 Attach the leg assembly to the testing device in such a manner that it does not move during impact testing (see diagram 10). In this situation, the center line of the femur load cell simulator is to be vertical within a range of $\pm 0.5^{\circ}$, and when the heels are placed upon 2 low friction plane sheets (PTFE sheets), adjust the fixtures so that the line connecting the U link knee joint and ankle joint fixture bolts are level within a range of $\pm 3^{\circ}$, and then adjust so that the fleshy part of the tibia is completely in the direction of the tibia's knee side. Furthermore, the bottom plane of the foot is vertical within a range of $\pm 3^{\circ}$, and at a right angle to the direction of impact, with the ankle joints adjusted so that the center line of the feet aligns in a straight line with the pendulum arm. The knee

joints are to be adjusted to a range of 1.5 ± 0.5 times empty weight prior to testing. Once the ankle joints have been adjusted so that they are free, the feet are to be fixed to the PTFE sheet sufficiently that they are stable.

1.7.1.1.5 The rigid impact device is to be composed of a horizontal cylinder 50 ± 2 mm in diameter and a pendulum support arm 19 ± 1 mm in diameter (see diagram 13). The mass of the cylinder, including the measuring devices and all support arm portions within the cylinder, is to be 1.25 ± 0.02 kg, with the pendulum arm having a mass of 285 ± 5 g. The distance between the center horizontal axis of the impact cylinder and the rotation axis of the entire pendulum is to be $1,250\pm 1$ mm. In this situation, the mass of the rotating portion attached to the support arm must not exceed 100g.

The impact cylinder is to be attached so that it has a level longitudinal axis and is perpendicular to the direction of impact, with the vertical center line of the pendulum arm set so that it is within a range of 1° from a vertical line at the time of impact, and so that the pendulum impacts with the bottom portion of the foot at a distance of 185 ± 2 mm from the top of the PTFE sheet of the heels set upon the rigid horizontal platform. The impact device is to be set so that it does not gyrate to the left or right, or up and down.

1.7.1.1.6 In cases where the same legs will be used for successive tests, an interval of at least 30 minutes must be placed between tests.

1.7.1.1.7 Data collection systems, including transducers, must conform to CFC 600 specifications.

1.7.1.2 Performance code

The maximum bending moment of the lower tibia centered on the Y axis (M_y) is when impact is 120 ± 25 Nm applied to the ball of each foot as stipulated in section 1.7.1.1 is to be 6.7 ± 0.1 m/s.

1.7.2 Impact tests to the bottom of the foot without shoes

1.7.2.1 Test procedures

1.7.2.1.1 Each leg assembly is to be stored for 4 hours prior to testing in a state with a temperature of $22\pm 3^\circ\text{C}$ and comparative humidity of $40\pm 30\%$. This does not include the time needed to reach this steady state.

1.7.2.1.2 Prior to testing, the impact surface of the upper legs and surface of the impact device are to be cleaned with isopropyl alcohol or a similar substance and freed of dust with talc. Furthermore, the energy absorption heel inserts to be checked to ensure there is no visible damage.

1.7.2.1.3 Adjust the accelerometer on the impact device so that the measurement axis is parallel to the vertical axis of the impact device.

1.7.2.1.4 Attach the leg assembly to the testing device in such a manner that it does not move during impact testing (see diagram 11). Attach the leg assembly in the same manner stipulated in section 1.7.1.1.4.

1.7.2.1.5 The rigid impact device is to be of the specifications stipulated in section 1.7.1.1.5, while the impact cylinder is to be attached so its vertical axis is level and perpendicular to the direction of impact, and set so that the vertical center line of the pendulum arm falls within a range of 1° from a perpendicular line at the time of impact, and so that the pendulum impacts with the bottom of the foot at a distance of 62 ± 2 mm from the top of the PTFE sheet of the heels set upon the rigid horizontal

platform. The impact device is to be set so that there is no significant gyration to the left or right, or up and down.

1.7.2.1.6 In cases where the same legs will be used for successive tests, and interval of at least 30 minutes must be placed between tests.

1.7.2.1.7 Data collection systems, including transducers, must conform to CFC 600 specifications.

1.7.2.2 Performance Code

The maximum acceleration of the impact device when impact is applied to the heel of each foot at $4.4 \pm 0.1 \text{ m/s}$ as stipulated in section 1.7.2.1 is to be $2,894 \pm 491 \text{ m/s}^2$ ($295 \pm 50 \text{ g}$).

1.7.3 Foot bottom impact test (with shoes)

1.7.3.1 Test procedure

1.7.3.1.1 Each leg assembly is to be stored for 4 hours prior to testing in a state with a temperature of $22 \pm 3^\circ \text{C}$ and comparative humidity of $40 \pm 30\%$. This does not include the time needed to reach this steady state.

1.7.3.1.2 After wiping down the bottom of the shoes and the impact surface with a clean cloth prior to testing, clean the surface of the impact device with isopropyl alcohol or a similar substance.

Furthermore, the energy absorption heel inserts to be checked to ensure there is no visible damage.

1.7.3.1.3 Adjust the accelerometer on the impact device so that the measurement axis is parallel to the vertical axis of the impact device.

1.7.3.1.4 Attach the leg assembly to the testing device in such a manner that it does not move during impact testing (see diagram 12). Attach the leg assembly in same manner stipulated in section 1.7.1.1.4.

1.7.3.1.5 The rigid impact device is to be of the specifications stipulated in section 1.7.1.1.5, while the impact cylinder is to be attached so its vertical axis is level and perpendicular to the direction of impact, and set so that the vertical center line of the pendulum arm falls within a range of 1° from a perpendicular line at the time of impact, and so that the pendulum impacts with the level surface of the heel of the shoes at a distance of $62 \pm 2 \text{ mm}$ from the top of the PTFE sheet of the dummy's heels when the shoes are set upon the rigid horizontal platform. The impact device is to be set so that there is no gyration to the left or right, or up and down.

1.7.3.1.6 In cases where the same legs will be used for successive tests, and interval of at least 30 minutes must be placed between tests.

1.7.3.1.7 Data collection systems, including transducers, must conform to CFC 600 specifications.

1.7.3.2 Performance code

In accordance with section 1.7.3.1, the maximum tibia compression (F_z) when impact is applied to the heels of shoes at $6.7 \pm 0.1 \text{ m/s}$ is to be $3.3 \pm 0.5 \text{ kN}$.

Diagram 10 - Upper foot impact tests (test device specifications)

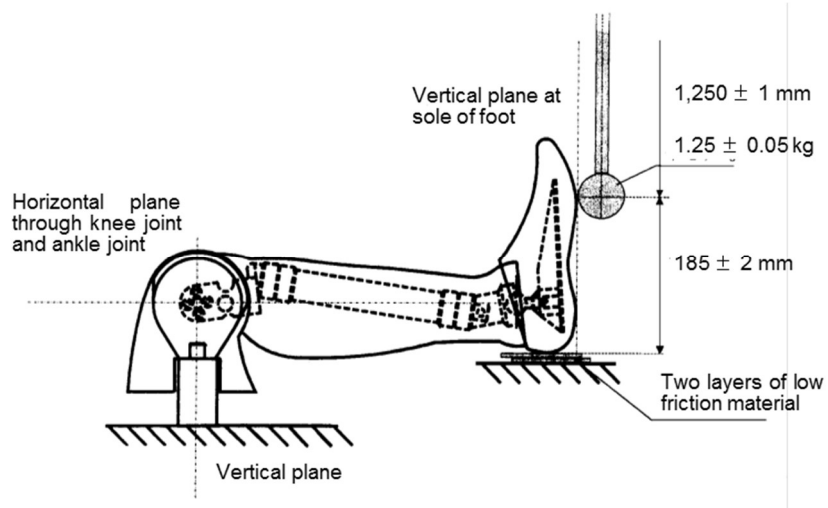

Diagram 11 - Lower foot impact tests (without shoes) (test device specifications)

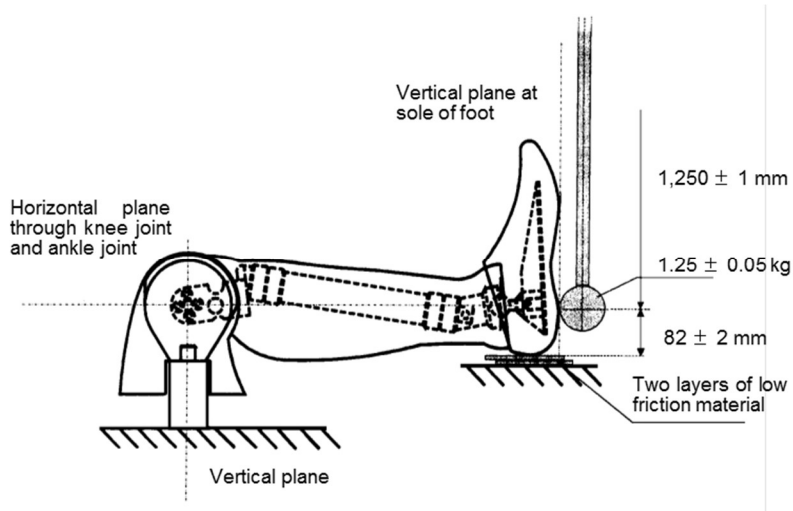

Diagram 12 - Lower foot impact tests (with shoes) (test device specifications)

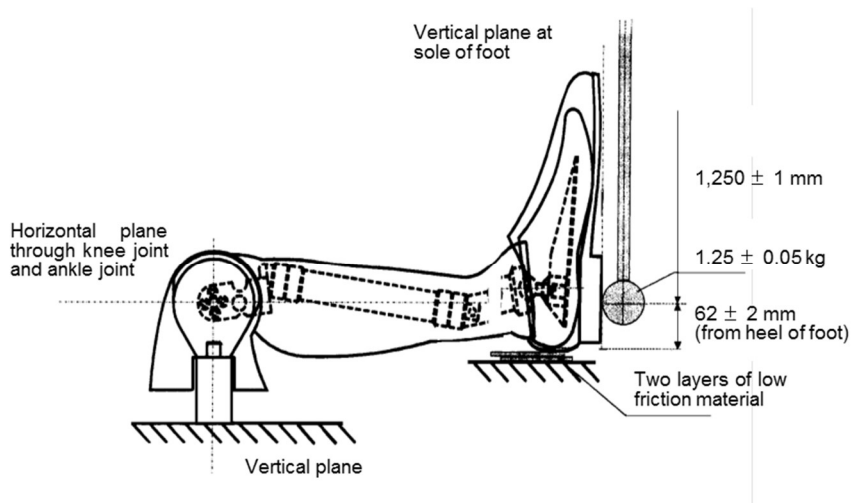
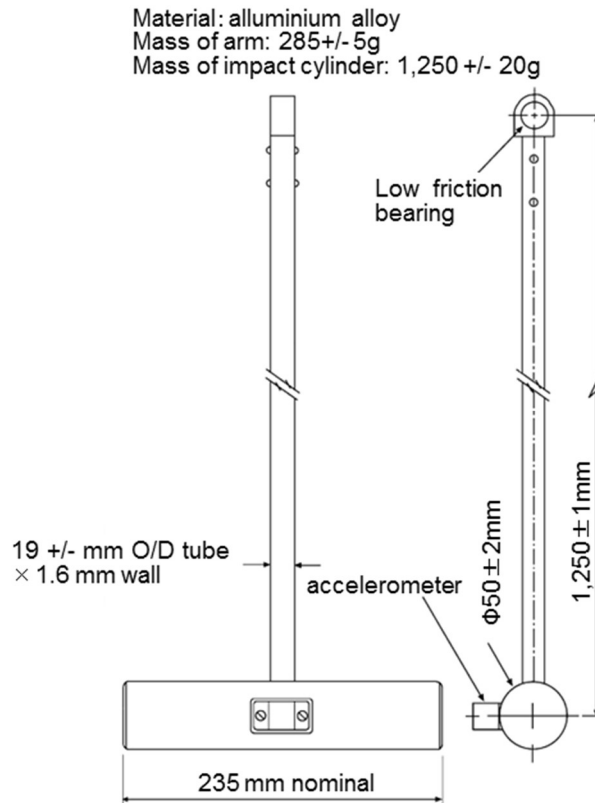

Diagram 13 - Pendulum impact device



1.8 Types of measurement instruments

(1) Head accelerometer sensitivity center

The head accelerometer sensitivity center is within the range depicted in the following table, with the center of the head (a point on the center plane of the dummy, 23 mm upwards from the bottom surface of the head interior and 63.5 mm in front of the vertical plane where the cranium and cranium cover meet) as a reference point. (See diagram 14)

	Range of center of sensitivity of head accelerometer (mm)		
	Fore-and-aft direction	Right-and-left direction	Up-and-down Direction
Range of fore-and-aft axis	Within 33	±5	±5
Range of right and left axis	±5	±33	±5
Range of up-and-down axis	±5	±5	±8

(2) Neck load indicator attachment

Neck load indicator attachment state is to be as depicted in diagram 14 and diagram 15.

Diagram 14 - Center of Sensitivity of Head Accelerometer and Installation of 3-axis Type Head Load Meter

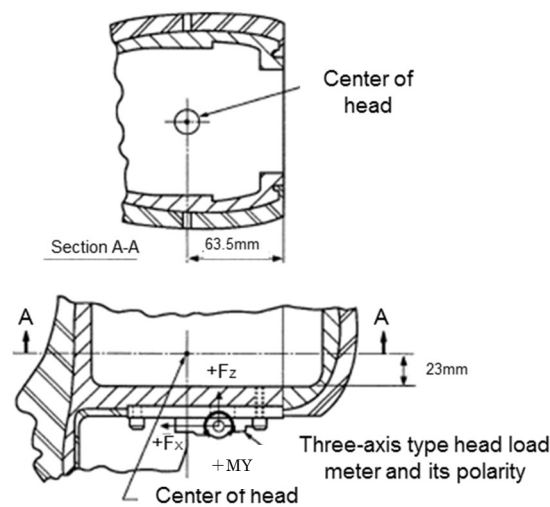
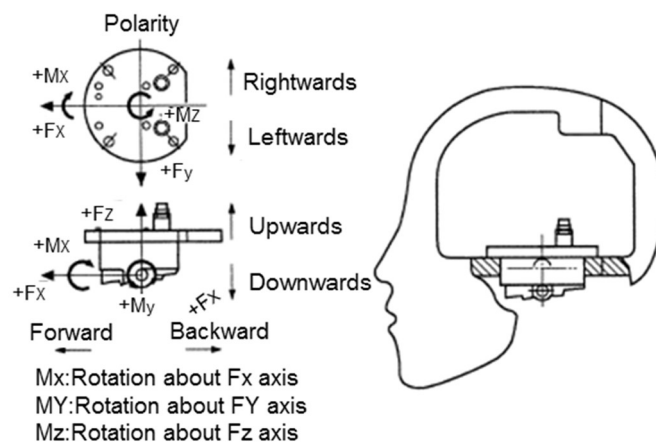

Figure 15 - Installation of 6-axis Type Head Load Meter



(3) Chest accelerometer sensitivity center

The chest accelerometer sensitivity center is within the range depicted in the following table, with the center of the head (a point on the center plane of the dummy, 97 mm downwards from the upper surface of the plate the neck fixture bracket is attached to, and at a position 94 mm in front of the rear end surface of the thoracic vertebrae) as a reference point. (See diagram 16 and diagram 17)

	Chest accelerometer sensitivity center range (mm)		
	Front-back direction	Left-right direction	Up-down direction
Front-back axis range	Rear Within 40	±10	Below Within 20
Left-right axis range	Rear Within 50	±5	Below Within 20
Up-down axis range	Rear Within 25	±10	Below Within 45

(4) Chest displacement gage attachment state

Chest displacement attachment state is to be as depicted in diagram 16.

Diagram 16 - Chest center and chest displacement gage attachment state

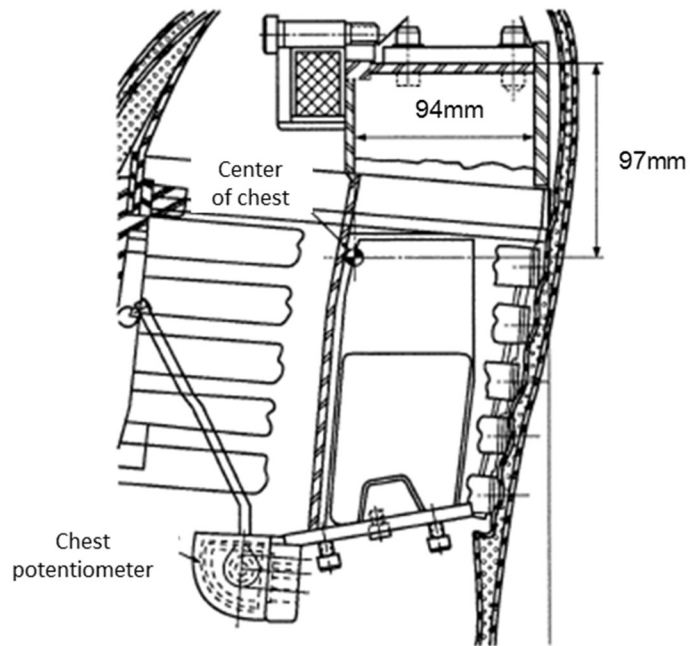
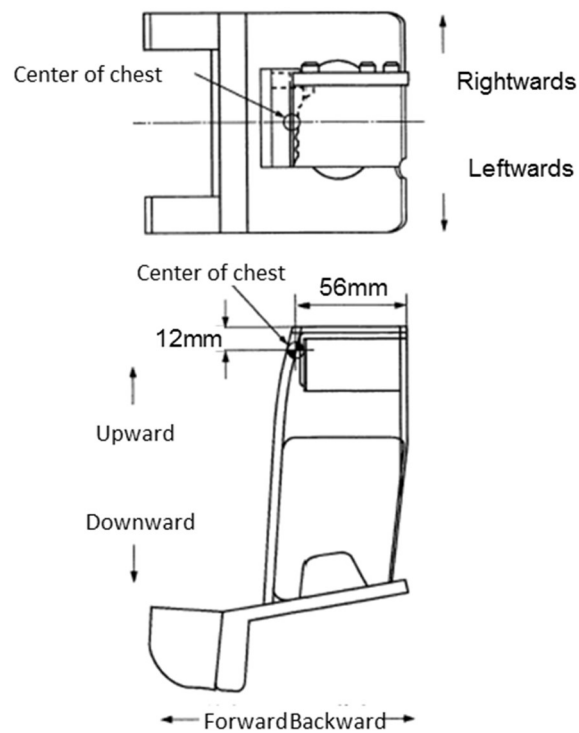

Diagram 17 - Chest accelerometer sensitivity center



HYBRID III DUMMY 5TH PERCENTILE INSPECTION METHOD**1. Inspection method and requirements**

In cases where it is necessary to inspect the features of each part of a dummy in accordance with sections 1.2 to 1.6, the dummy may be dismantled and put together. Furthermore, the measurement of structural dimensions in section 1.1 are to be completed after all inspections of sections 1.2 to 1.6 have been completed and the dummy has been assembled back into its proper state. Tape may be used with the intent of maintaining the dummy's posture when measuring the dummy's dimensions and inspecting its features.

1.1 Structural dimensions

The dimensions of each part when measuring dummy part dimensions are to be as indicated in diagram 1.

Diagram 1 - Hybrid III structural dimensions

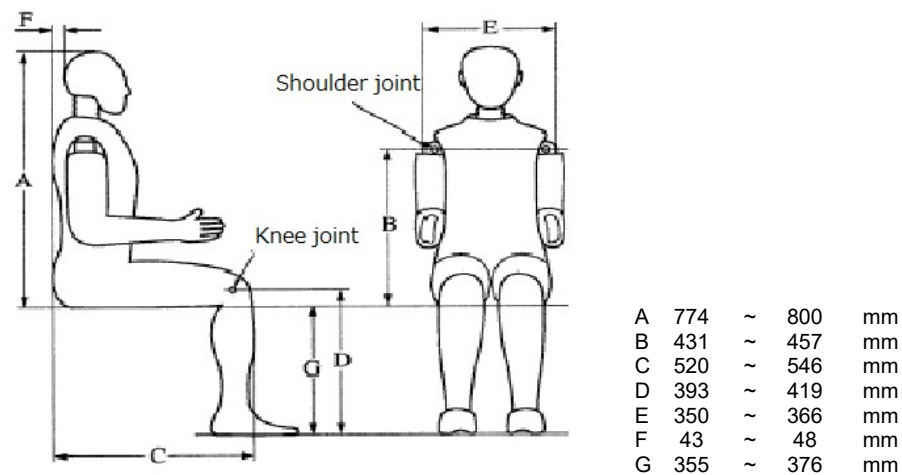
**1.2 Head features**

When conducting inspection tests following the procedure below, the maximum resultant acceleration value when the head is falling is to be between 2,450m/s² and 2,940m/s², and the maximum value of the waveform that occurs after the main waveform (referred to as the maximum waveform) on a resultant head acceleration/time curve is to be under 10% of the maximum value of the main waveform. Furthermore, the maximum value of the left-right acceleration is to be under 147m/s².

- (1) The inspected head is to be stored for over 4 hours in environment conditions maintained such that temperature is between 18.9°C and 25.6°C, and humidity is between 10% and 70%.
- (2) Suspend the head so that the lowest point of the forehead is 13±1 mm lower than the lowest point of the dummy's nose is at a height of 376±3mm as depicted in diagram 2. When it is dropped on an iron plate of at least 50 mm thickness with a surface roughness between 0.0002mm (ms) and

0.002mm (ms), measure the 3 axes (front-back, left-right, and up-down directions) acceleration and find the maximum resultant acceleration value. When doing so, attach a Neck Transducer substitute structure to place the head in a state as if it were actually attached.

(3) When inspecting the same head successively, an interval of at least 3 hours in the environmental conditions stipulated in (1) must left between tests.

Diagram 2 - Head features test

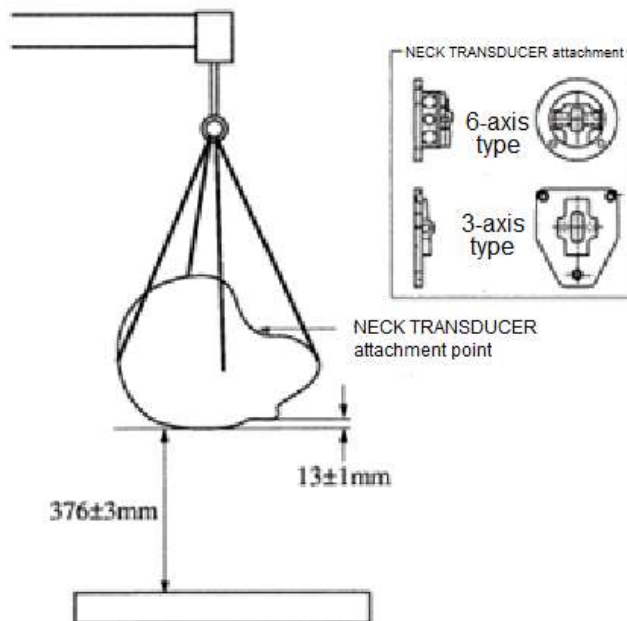

1.3 Neck features

When conducting inspection tests following the procedure below, curve side (the side the neck contracts on) features and expansion side (the side the neck extends on) are each depicted in the following table.

Curve side features	<ul style="list-style-type: none"> ① The moment measured by the neck measurement instruments is to have a maximum value between 69N·m and 83N·m when plane D in diagram 3 is within a range of 77° and 91° to the pendulum. ② The positive moment (the moment where direction is the same as direction of pendulum rotation) is to first decay to 10Nm between 80ms and 100ms after collision.
Expansion side features	<ul style="list-style-type: none"> ① The moment measured by the neck measurement instruments is to have a maximum value between 65N·m and 53N·m when plane D in diagram X 4 is within a range of 99° and 114° to the pendulum. ② The negative moment (the moment where direction is the opposite direction of pendulum rotation) is to first decay to -10Nm between 94ms and 114ms after collision.

Diagram 3 - Neck curve side features

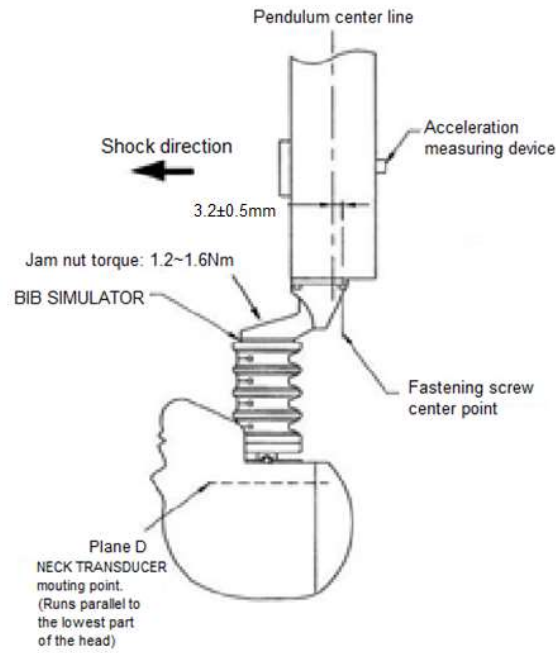

Sample rotation angle measurement methods

- Affix a displacement sensor to measure and calculate
- Film analysis using high-speed photography.

Diagram 4 - Neck expansion side features

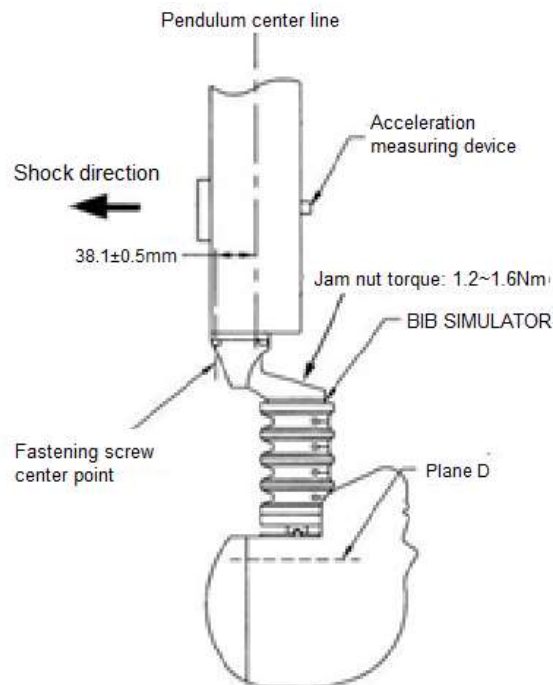

(1) The inspected neck is to be stored for over 4 hours in environment conditions maintained such that temperature is between 20.6°C and 22.2°C, and humidity is between 10% and 70%.

- (2) Before inspection, tighten the jam nuts of the neck cable with a torque between 1.2Nm and 1.6Nm.
- (3) Attach the neck and head to the pendulum as indicated in the diagram 5 with face facing the direction of collision (curve side inspection) and the opposite direction (expansion side inspection). When doing so, attach a bib simulator (see diagrams 3 and 4) to simulate an actual attached state, with plane D being perpendicular to the center line of the pendulum. However, a head for inspection purposes only with an inspection displacement sensor attached may be used for the head.
- (4) The pendulum is to be swung to cause collision at speeds of between 6.89m/s and 7.13m/s for curve side inspections, and between 5.95m/s and 6.19m/s for expansion side inspections, with the rotation angle and moment at these times measured and calculated. Neck moment is calculated according to the following formula.

$$M = M_y - 0.01778(M) \times F_x$$

In this case,

M is neck moment (unit: Nm)

M_y is neck measurement instrument moment (unit: Nm)

F_x is the x axial force of the neck measurement instrument (unit: N)

- (5) In curve inspections, the speed of the pendulum at the time of collision corresponds to the elapsed time post collision indicated in the left column of table A, with each range value in the right column of table A. Furthermore, in expansion inspections the speed of the pendulum at the time of collision corresponds to the elapsed time post collision indicated in the left column of table B, with each range value in the right column of table B.

Diagram 5 - Neck feature test

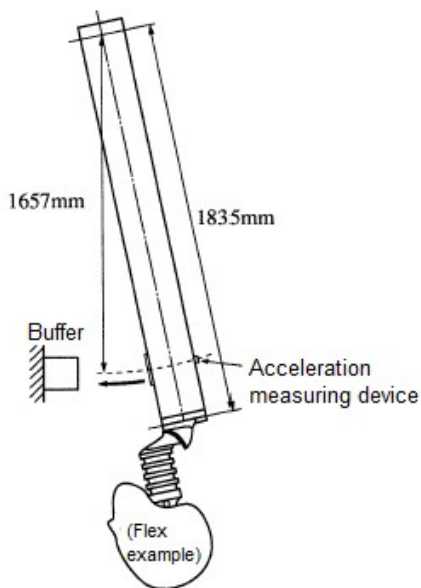

Table A

Time(ms)	Speed Range(m/s)
10	2.1~2.5
20	4.0~5.0
30	5.8~7.0

Table B

Time(ms)	Speed Range(m/s)
10	1.5~1.9
20	3.1~3.9
30	4.6~5.6

(6) When using the same neck for the test successively, an interval of at least 30 minutes in the environmental conditions stipulated in (1) must left between tests.

1.4 Chest features

The potentiometer used with the chest is to be SAE J2517 compliant.

1.4.1 High speed side features

When applying impact to the chest with an impact device according to the following procedures, the maximum value of the impulsive force occurring in the impact device is to be between 390daN and 440daN, with the maximum displacement value of the sternum in relation to the vertebral column is to be between 50mm and 58mm. Furthermore, impulsive force within the impact device must not exceed 460daN displacement value of the sternum in relation to the vertebral column is between 18mm and 50mm. Internal hysteresis during impact is to be within a range of 69% and 85%.

- (1) The inspected chest is to be stored for at least 4hours in environment conditions maintained such that temperature is between 20.6°C and 22.2°C, and humidity is between 10% and 70%.
- (2) As indicated in the diagram, sit the dummy on a level surface without its back or elbows resting against anything, and with the shoulder and elbow joints lightly tightened so that the upper arms thrust forward, with the pelvis angle adjusted between $7^{\circ} \pm 2^{\circ}$. In this situation the dummy may be dressed in a shirt and pants as stipulated in 3.2.9.2.(3).

Diagram 6 - Chest feature test

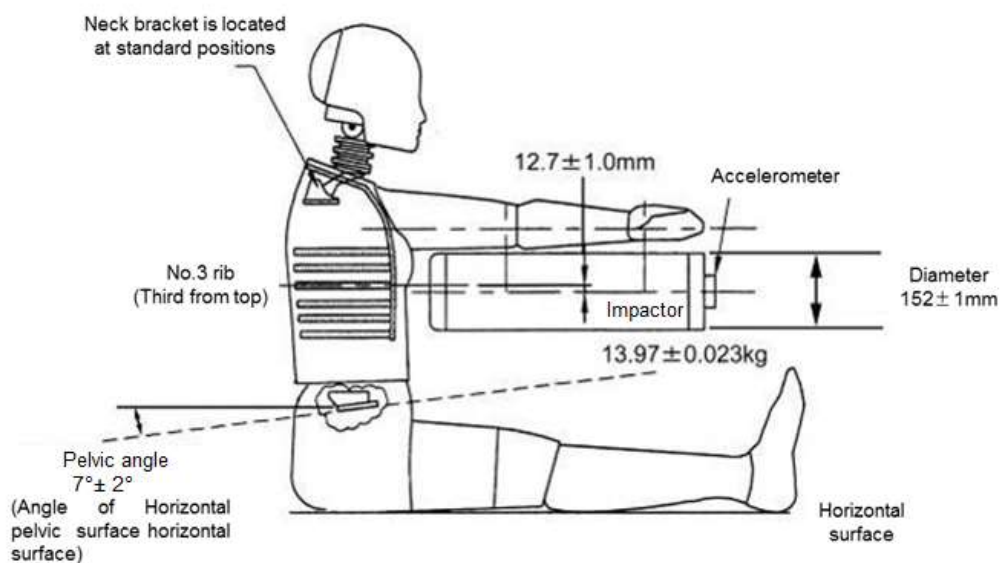

- (3) Adjust the positional relationship between the impact device and rib no. 3 in such a manner that the longitudinal direction center line extending from the impact device is 12.7 ± 1.0 mm lower than the horizontal center line of rib no. 3 on the dummy's center plane.

- (4) Collide the impact device with the chest at a speed between 6.59m/s and 6.83m/s, with the deceleration that occurs at the rear end of the impact device at this time the displacement of the sternum in regards to the dummy's vertebral column (measured with a displacement gage attached inside the sternum), then measure and calculate the impulsive force occurring in the impact device (the product of the impact device's mass and deceleration), and the hysteresis (the comparison (A/B) of the area A between the load of the force displacement curve and the unloaded portion, and the area B below said curve's loaded portion (see diagram 7)).
- (5) When inspecting the same chest successively, an interval of at least 30 minutes in the environmental conditions stipulated in (1) must left between tests.

Diagram 7 - Chest feature inspection load/displacement curve

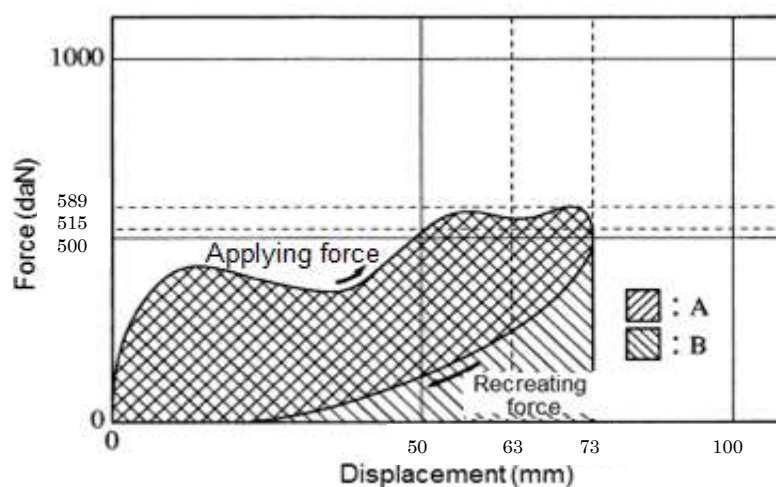

1.4.2 Low speed side features

When applying impact to the chest with an impact device according to the following procedures, the maximum value of the impulsive force occurring in the impact device is to be between 178daN and 207daN, with the maximum displacement value of the sternum in relation to the vertebral column is to be between 17.4mm and 21.8mm. Furthermore, internal hysteresis during impact is to be within a range of 65% and 79%.

- (1) The inspected chest is to be stored for at least 4 hours in environment conditions maintained such that temperature is between 20.6°C and 22.2°C, and humidity is between 10% and 70%.
- (2) As indicated in diagram 8, sit the dummy on a level surface without its back or elbows resting against anything, and with the shoulder and elbow joints lightly tightened so that the upper arms thrust forward, with the pelvis angle adjusted between $7^{\circ} \pm 2^{\circ}$. In this situation the dummy may be dressed in a shirt and pants as stipulated in 4.2.9.2.(3).

Diagram 8 - Chest feature test

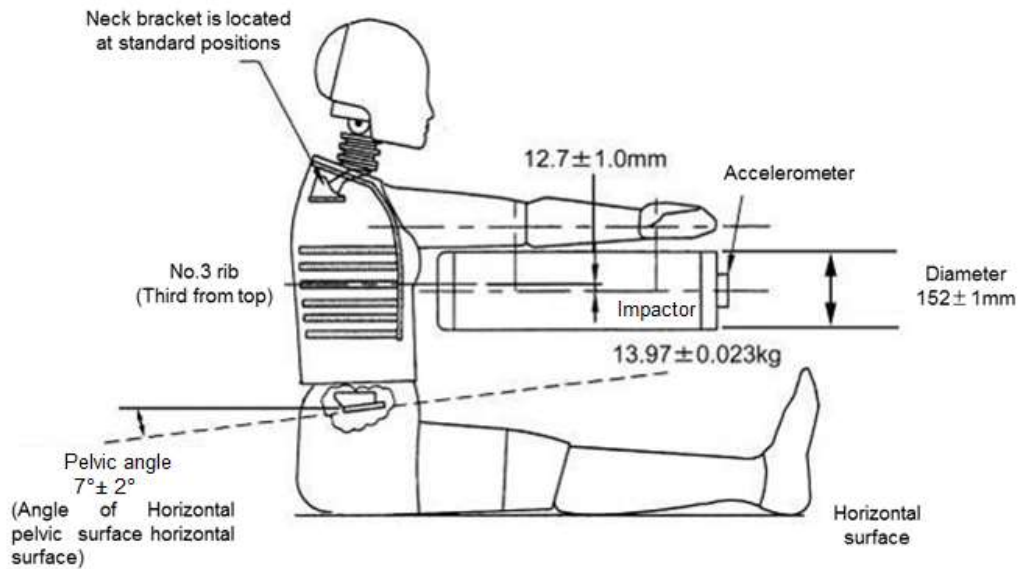

- (3) Adjust the positional relationship between the impact device and rib no. 3 in such a manner that the longitudinal direction center line extending from the impact device is $12.7 \pm 1.0\text{mm}$ lower than the horizontal center line of rib no. 3 on the dummy's center plane.
- (4) Collide the impact device with the chest at a speed between 2.95m/s and 3.05m/s , with the deceleration that occurs at the rear end of the impact device at this time the displacement of the sternum in regards to the dummy's vertebral column (measured with a displacement gage attached inside the sternum), then measure and calculate the impulsive force occurring in the impact device (the product of the impact device's mass and deceleration), and the hysteresis (the comparison A/B of the area A between the load of the force displacement curve and the unloaded portion, and the area B below said curve's loaded portion (see diagram 9)).
- (5) When inspecting the same chest successively, an interval of at least 30 minutes in the environmental conditions stipulated in (1) must left between tests.

Diagram 9 - Chest feature inspection load/displacement curve

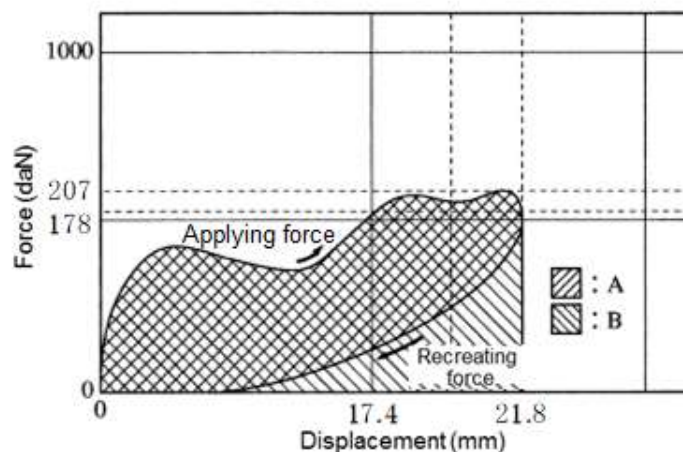

1.5 Lumbar bend features

As indicated in diagram 10, when bending the upper body forward according to the following procedures, the weight pulling the upper body when the angle of the upper body and legs is between 44.5° and 45.5° should be within a range of 320N and 390N. Furthermore, the upper body should return to within 8° of its initial angle when the weight is removed.

- (1) The inspected dummy is to be stored for at least 4 hours in environment conditions maintained such that temperature is between 18.9°C and 25.6°C , and humidity is between 10% and 70%.
- (2) Set the dummy on the platform and, while keeping the surface where the pelvis and lumbar join level, fix the pelvis in place with a pelvis fixture tool. Furthermore, affix a tool for loading stress to the vertebral column.
- (3) Bend the upper body of the dummy forward until it is 30° from the vertical plane. After repeating this process 3 times, leave 30 minutes before conducting the test. During this time, apply external support to keep the upper body of the dummy vertical.
- (4) Remove the tools keeping the dummy in place, and after waiting 2 minutes measure the angle of the upper body (initial angle). This initial angle should be within 20° .
- (5) Attach the wire and load indicator to the device for applying load stress, bend the upper body forward to $45\pm 0.5^\circ$ at a speed between $0.5^\circ/\text{sec}$ and $1.5^\circ/\text{sec}$, then measure the load while maintaining this position for 10 seconds.
- (6) Quickly remove all load from the device for applying load stress and measure the amount of change between the upper body angle and initial angle 3 minutes later.

Diagram 10 - Lumbar bend feature test

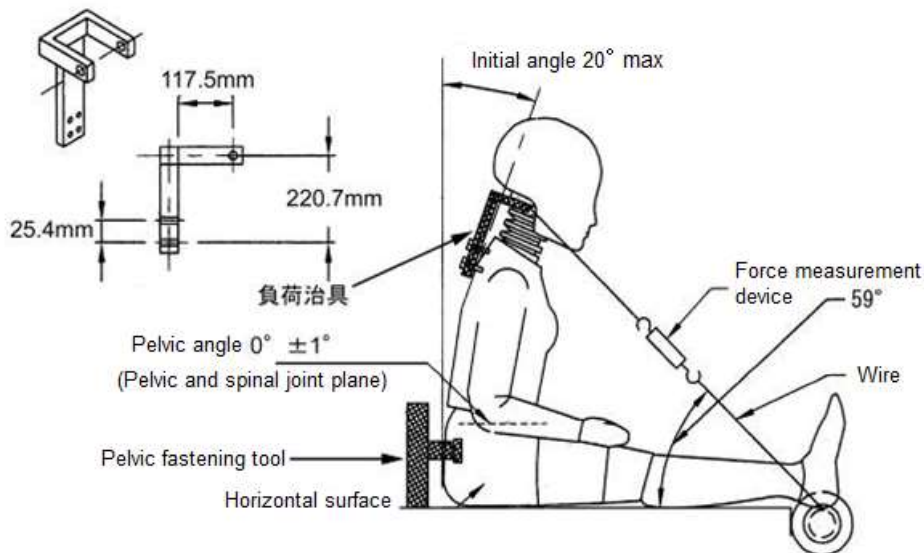

1.6 Leg features

When applying impact to the right and left knees of the legs with an impact device according to the following procedures, the maximum value of the impact load occurring in the impact device (a cylinder with the portion applying impact $76\pm 1\text{mm}$ in diameter). In order to measure the acceleration of the impact device that occurs along the center line of the cylinder's longitudinal direction, an

accelerometer is to be attached to the surface of the impact device on the side opposite the side of impact in such a manner that it overlaps this same line. Furthermore, the mass of the impact device is to be $2.99 \pm 0.023 \text{ kg}$ including the accelerometer.) is to be within 345daN and 406daN. (See diagram 11)

- (1) The inspected legs are to be stored for at least 4 hours in environment conditions maintained such that temperature is between 18.9°C and 25.6°C , and humidity is between 10% and 70%.
- (2) Adjust the position of the impact device so that, when the impact device comes into contact with the knees in a level state, the height of the impact device's longitudinal direction center line is the same as the height of the center line of the knee pivot bolts on a vertical plane passing through the femur's center line.
- (3) Collide the impact device with the knees at a speed between 2.07 m/s and 2.13 m/s , with the deceleration that occurs at the rear end of the impact device at this time, and the impulsive force occurring in the impact device (the product of the impact device's mass and deceleration) measured and calculated.
- (4) When inspecting the same legs successively, an interval of at least 30 minutes in the environmental conditions stipulated in (1) must left between tests.

Diagram 11 - Leg feature test

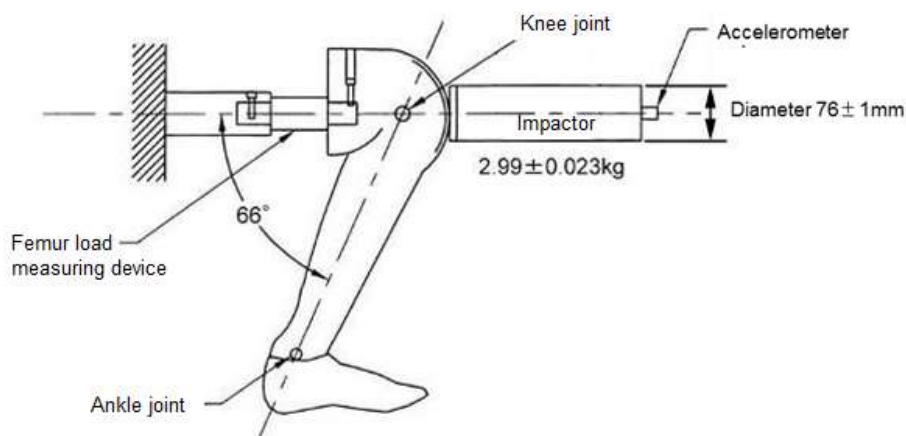

1.7 Types of measurement instruments

(1) Head accelerometer sensitivity center

The head accelerometer sensitivity center is within the range depicted in the following table, with the center of the head (a point on the center plane of the dummy, 30.5mm upwards from the bottom surface of the head interior and 59.2mm in front of the vertical plane where the cranium and cranium cover meet) as a reference point. (See diagram 12)

	Head accelerometer sensitivity center range (mm)		
	Front-back direction	Left-right direction	Up-down direction
Front-back axis range	Rear Within 33	±5	±5
Left-right axis direction	±5	±33	±5
Up-down axis range	±5	±5	±8

Diagram 12 - Head accelerometer sensitivity center

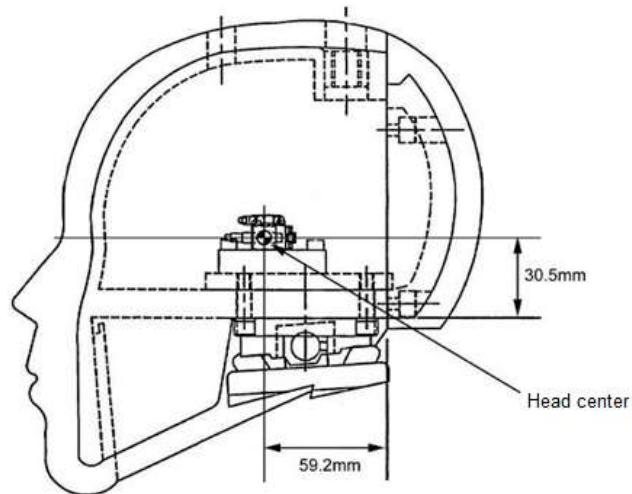

(2) Neck load indicator attachment state

Neck load indicator attachment state is to be as depicted in diagram 13.

Diagram 13 - Axial neck load indicator attachment state

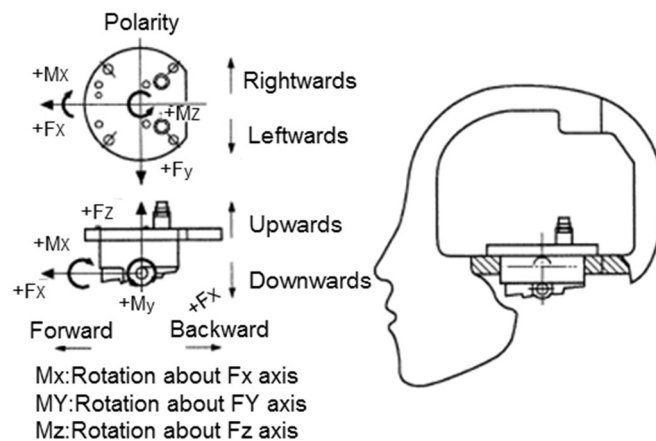

(3) Chest accelerometer sensitivity center

The chest accelerometer sensitivity center is within the range depicted in the following table, with the center of the chest (a point on the center plane of the dummy, 86mm downwards from the upper surface of the spine, and at a position 83mm in front of the rear end surface of the thoracic vertebrae) as a reference point. (See diagram 14)

	Chest accelerometer sensitivity center range (mm)		
	Front-back direction	Left-right direction	Up-down direction
Front-back axis range	Rear Within 40	±10	Below Within 20
Left-right axis direction	±Rear Within 50	±5	Below Within 20
Up-down axis range	Rear Within 25	±10	Below Within 45



(4) Chest displacement gage attachment state

Chest displacement attachment state is to be as depicted in diagram 14.

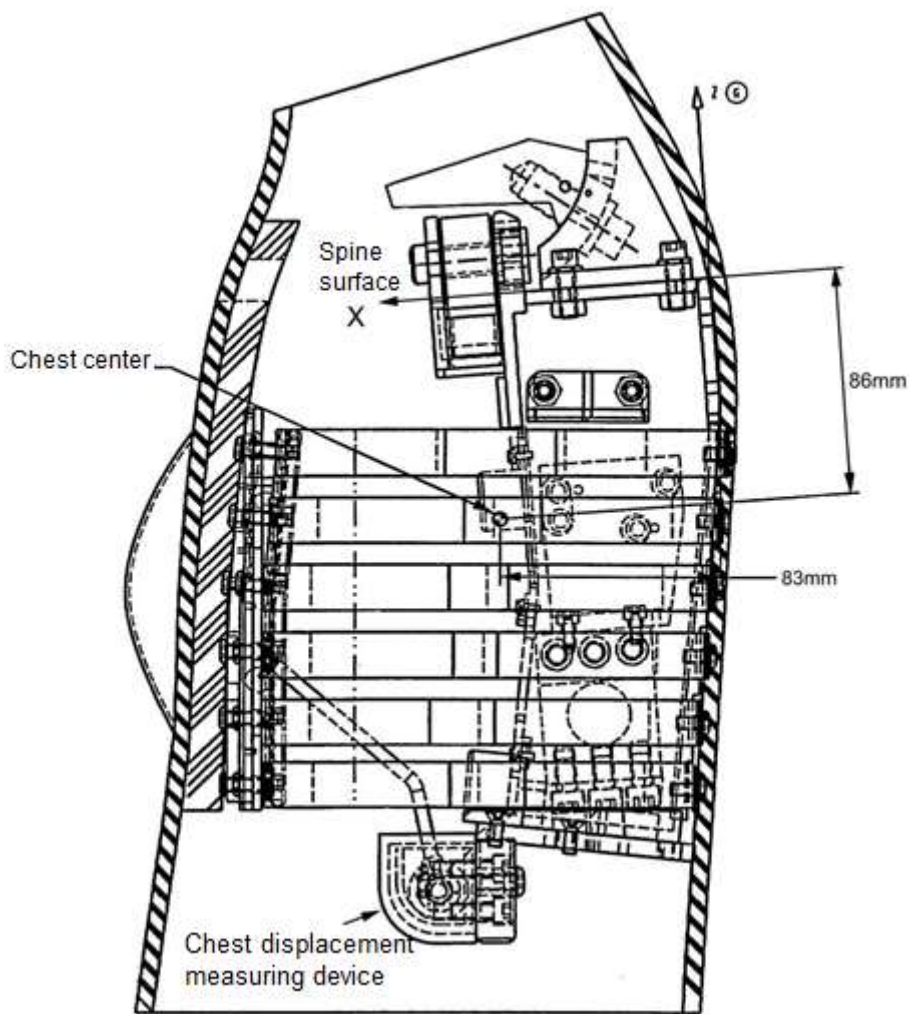
Diagram 14 - Chest center and chest displacement gage attachment state

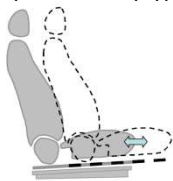
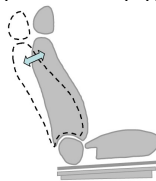
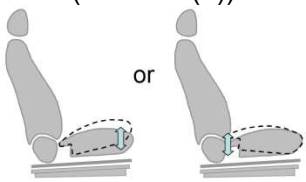
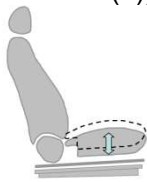
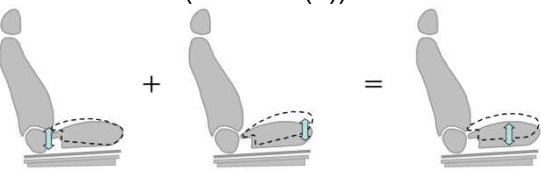
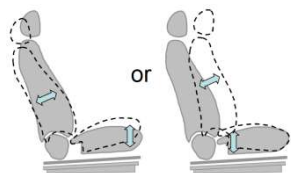
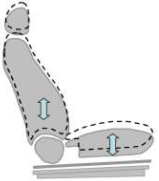
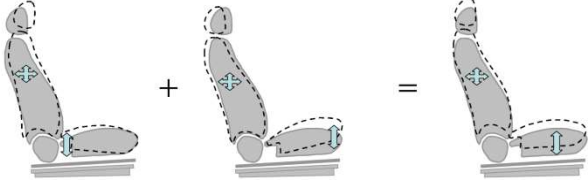
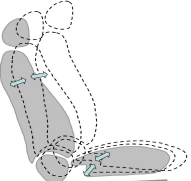

Adjusting Position of Test Seat Adjustment Mechanism

<p>Fore-and-aft direction adjustment device (ref.4.1.5.(1))</p>  <p>Middle position in fore-and-aft direction</p>	<p>Seat back angle adjustment device (ref.4.1.5.(3))</p>  <p>Design standard angle</p>
<p>Seat cushion surface angle adjustment device(tilt or lifter) (ref.4.1.5.(5))</p>  <p>Design standard position</p>	<p>Seat cushion surface up-and-down adjustment device(lifter) (ref.4.1.5.(2))</p>  <p>Lowermost position in up-and-down direction</p>
<p>Seat cushion surface angle up-and-down adjustment device(others) (ref.4.1.5.(5))</p>  <p>Design standard position</p>	<p>Seat lower-seat back angle adjustment device (ref.4.1.5.(5))</p>  <p>Design standard position</p>
<p>Seat lower-seat back up-and-down adjustment device(lifter) (ref.4.1.5.(2))</p>  <p>Lowermost position in up-and-down direction</p>	<p>Seat lower(angle, up-and-down)-seat back angle adjustment device (ref.4.1.5.(5))</p>  <p>Design standard position</p>
<p>Fore-and-aft, up-and-down, angle all linked adjustment device (ref.4.1.5.(5))</p>  <p>Design standard position</p>	<p>Fore-and-aft, up-and-down all linked adjustment device (lifter) (ref.4.1.5.(2))</p>  <p>Lowermost position in up-and-down direction</p>

TEST RESULTS REPORT (SAMPLE)

Full Wrap Front End Collision

Test No. NASVA 2018_****_***

Test Vehicle Name: NASVA 1234

Test Date : 2018/**/** (*)

Test Location : Japan Automobile Laboratory, Inc.

1. Test Automobile

Vehicle Name/Model : NASVA 1234(DAA-ABCD)

Test Vehicle Weight : 1000kg (F:600/R:400)

Frame Number : ABCD-123456

Occupant Crash Protection : Driver Seat - seatbelt (w/ double pretensioner
+ airbag (Front, side, curtain)
Passenger Seat - seatbelt (w/ pretensioner)
+ airbag (front, side, curtain)

2. Dummies

Driver Seat : Hybrid-III 50%tile No. J-01 (N-01)

Passenger Seat : Hybrid-III 05%tile No. DT01-1

3. Test Scores

① Collision Speed : 55.0km/h

② Center Displacement : Left-right 0mm Up-down 0mm

③ Injury Value :

				Driver Seat	Passenger Seat
HIC36				123.4	
HIC15					123.4
Head & Neck	Pull Load (kN)				1.2
	Shear Load (kN)				1.2
	Rear Moment (Nm)		-12.34	-12.34	
Chest Acceleration 3ms-G (m/s ²)				123.45	
Chest Displacement (mm)				-12.34	-12.34
Chest & Steering Contact				None	
Waist Belt Displacement	Right				None
	Left				None
Femoral Load	Right (kN)		-1.23	-1.23	
	Left (kN)		-1.23	-1.23	
Right Tibia	Upper TibiaIndex	Comp. Load (kN)	1.23	-1.23	
	Lower TibiaIndex	Comp. Load (kN)	1.23	-1.23	
Left Tibia	Upper TibiaIndex	Comp. Load (kN)	1.23	-1.23	
	Lower TibiaIndex	Comp. Load (kN)	1.23	-1.23	

④ Vehicle Body Deformation :

Steering Deformation (mm)	Retraction	Forward 0
	Upward Shift	Down 0
Brake Pedal Deformation (mm)	Retraction	Back 0
	Upward Shift	Up 0

⑤ Dummy Constraint Condition During & After Testing:

- Driver Seat **Acceptable**
- Passenger Seat **Acceptable**

⑥ Waveform Removal in Secondary Collision: **Not implemented for driver or passenger seat**

⑦ Fuel Leakage During or After Collision: **None**

⑧ Side Door Openability:

		Left Side	Right Side
Front	Openability	One Hand	One Hand
	Door Lock	No Lock	No Lock
Back	Openability	One Hand	One Hand
	Door Lock	No Lock	No Lock

⑨ Belt Draw, Pull Amounts:

	Driver Seat	Passenger Seat
Pull	123mm	123mm
Draw	123mm	123mm

⑩ Dummy Removability:

- Driver Seat **Manpower**
- Passenger Seat **Manpower**

Notes

4. Dummy Seated Positions

(1) Point to Point Measurement Results

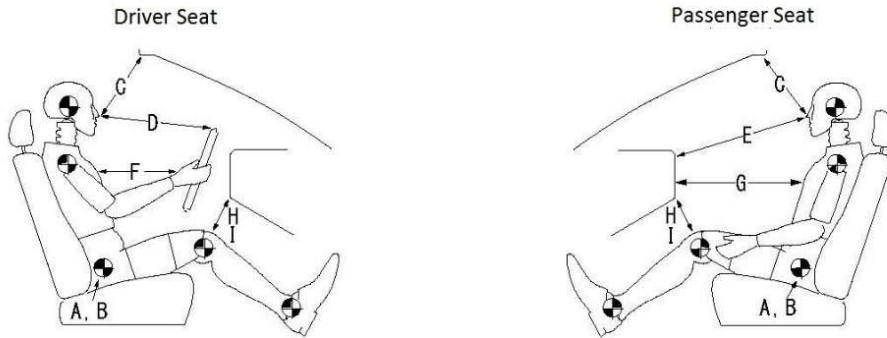

Units: mm

Measured Position	Driver Seat	Passenger Seat
A Reference point (Fr door checker bolt head)~hip point front-back	123	123
B Reference point (Fr door checker bolt head)~hip point up-down	123	123
C Nose tip~windshield header	123	123
D Nose tip~steering wheel rim top center	123	
E Nose tip~dashboard		123
F Chest~steering horn pad (horizontal)	123	
G Chest~dashboard (horizontal)		123
H Right knee~dashboard bottom	123	123
I Left knee~dashboard bottom	123	123
J Head angle	0°	0°
K Pelvis angle	22.5°	20.0°

Seatbelt Settings

Driver Seat

Passenger Seat

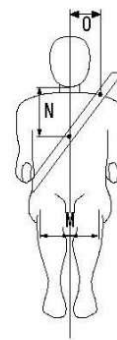
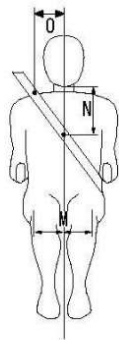

Measured Position	Driver Seat	Passenger Seat
M Knee interval (dummy center~left, right)	123 / 123	123 / 123
N Dummy chin bottom~belt center (up-down on dummy center line)	123	123
O Dummy center~belt center (left-right at height of neck base)	12	12

(2) Three-dimensional Measurement Results

Driver Seat

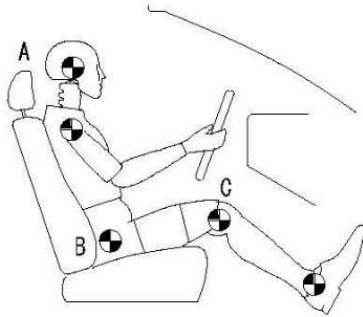

Passenger Seat

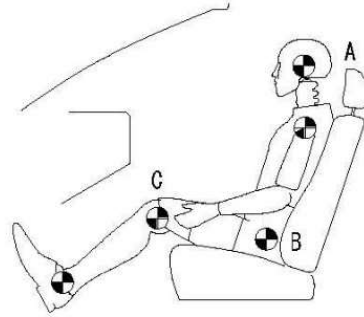

Reference Points: Driver Seat - Fr door checker bolt head (X;1234.5Y;123.4 Z;123.4)

Passenger Seat - Fr door checker bolt head (X;1234.5Y;-123.4 Z;123.4)

Unit: mm

Measured Part	Driver Seat			Passenger Seat		
	X	Y	Z	X	Y	Z
A: Head (outside)	1234	123	1234	1234	123	1234
B: Waist (outside)	1234	123	1234	1234	123	1234
C: Knee (outside)	1234	123	1234	1234	123	1234

5. Vehicle Body Part Deformation Amounts

(1) Cabin Interior Part Deformation Amounts

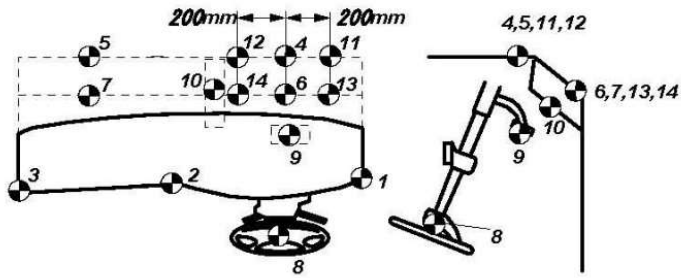

- 1: Instrument panel right end
- 2: Instrument panel center
- 3: Instrument panel left end
- 4: Driver seat toe board
- 5: Passenger seat toe board
- 6: Driver seat floor
- 7: Passenger seat floor
- 8: Steering shaft tip
- 9: Brake pedal
- 10: Foot rest
- 11: Driver seat toe board right
- 12: Driver seat toe board left
- 13: Driver seat floor right
- 14: Driver seat floor left

Reference point: Luggage room rear (X is positive in back direction, Y is positive in right direction, and Z is positive in upward direction)

Units: mm

Cabin Interior

Part	Pre Test	Post Test	Amount	
1	X	1234	1234	0
	Y	123	123	0
	Z	1234	1234	0
2	X	1234	1234	0
	Y	123	123	0
	Z	1234	1234	0
3	X	1234	1234	0
	Y	123	123	0
	Z	1234	1234	0
4	X	1234	1234	0
	Y	123	123	0
	Z	1234	1234	0
5	X	1234	1234	0
	Y	123	123	0
	Z	1234	1234	0
6	X	1234	1234	0
	Y	123	123	0
	Z	1234	1234	0
7	X	1234	1234	0
	Y	123	123	0
	Z	1234	1234	0

Part	Pre Test	Post Test	Amount	
8	X	1234	1234	0
	Y	123	123	0
	Z	1234	1234	0
9	X	1234	1234	0
	Y	123	123	0
	Z	1234	1234	0
10	X	1234	1234	0
	Y	123	123	0
	Z	1234	1234	0
11	X	1234	1234	0
	Y	123	123	0
	Z	1234	1234	0
12	X	1234	1234	0
	Y	123	123	0
	Z	1234	1234	0
13	X	1234	1234	0
	Y	123	123	0
	Z	1234	1234	0
14	X	1234	1234	0
	Y	123	123	0
	Z	1234	1234	0

(2) Door Vicinity Deformation

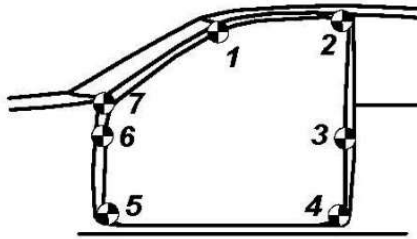

- 1: A pillar top
- 2: B pillar top
- 3: Striker bolt
- 4: B pillar bottom
- 5: A pillar bottom
- 6: A pillar center
- 7: A pillar fitting

Reference point: Luggage room rear (X is positive in back direction, Y is positive in right direction, and Z is positive in upward direction)

Units: mm

Right Door

Part		Pre Test	Post Test	Amount
1	X	1234	1234	0
	Y	123	123	0
	Z	1234	1234	0
2	X	1234	1234	0
	Y	123	123	0
	Z	1234	1234	0
3	X	1234	1234	0
	Y	123	123	0
	Z	1234	1234	0
4	X	1234	1234	0
	Y	123	123	0
	Z	1234	1234	0
5	X	1234	1234	0
	Y	123	123	0
	Z	1234	1234	0
6	X	1234	1234	0
	Y	123	123	0
	Z	1234	1234	0
7	X	1234	1234	0
	Y	123	123	0
	Z	1234	1234	0

Left Door

Part		Pre Test	Post Test	Amount
1	X	1234	1234	0
	Y	123	123	0
	Z	1234	1234	0
2	X	1234	1234	0
	Y	123	123	0
	Z	1234	1234	0
3	X	1234	1234	0
	Y	123	123	0
	Z	1234	1234	0
4	X	1234	1234	0
	Y	123	123	0
	Z	1234	1234	0
5	X	1234	1234	0
	Y	123	123	0
	Z	1234	1234	0
6	X	1234	1234	0
	Y	123	123	0
	Z	1234	1234	0
7	X	1234	1234	0
	Y	123	123	0
	Z	1234	1234	0